

Variable Permanent Magnet Quadrupole*

T. Mihara, Y. Iwashita
Kyoto University, Gokasho Uji, Kyoto 611-0011 Japan

M. Kumada
National Institution of Radiological Sciences, Inage-ku, Chiba 263-8555 Japan

C.M. Spencer
Stanford Linear Accelerator Center, Stanford University, Stanford, California 94309

Abstract

A permanent magnet quadrupole (PMQ) is one of the candidates for the final focus lens in a linear collider. An over 120 T/m strong variable permanent magnet quadrupole is achieved by the introduction of saturated iron and a 'double ring structure'. A fabricated PMQ achieved 24 T integrated gradient with $\phi 20$ mm bore diameter, $\phi 100$ mm magnet diameter and 20 cm pole length. The strength of the PMQ is adjustable in 1.4 T steps, due to its 'double ring structure': the PMQ is split into two nested rings; the outer ring is sliced along the beam line into four parts and is rotated to change the strength. This paper describes the variable PMQ from fabrication to recent adjustments.

To be published in IEEE Trans.Appl.Superconductivity

* Work supported in part by Department of Energy contract DE-AC02-76SF00515.

Variable Permanent Magnet Quadrupole

T. Mihara, Y. Iwashita, M. Kumada and C. M. Spencer

Abstract—A permanent magnet quadrupole (PMQ) is one of the candidates for the final focus lens in a linear collider. An over 120 T/m strong variable permanent magnet quadrupole is achieved by the introduction of saturated iron and a ‘double ring structure’. A fabricated PMQ achieved 24 T integrated gradient with $\phi 20$ mm bore diameter, $\phi 100$ mm magnet diameter and 20 cm pole length. The strength of the PMQ is adjustable in 1.4 T steps, due to its ‘double ring structure’: the PMQ is split into two nested rings; the outer ring is sliced along the beam line into four parts and is rotated to change the strength. This paper describes the variable PMQ from fabrication to recent adjustments.

Index Terms—Accelerators, Accelerator magnets, Permanent magnets, Linear accelerators.

I. INTRODUCTION

A PERMANENT MAGNET QUADRUPOLE (PMQ) achieved 300T/m in a $\phi 14$ mm bore by the introduction of saturated iron [1]. It is based on a modified Halbach magnet configuration [2],[3]. This makes use of saturated iron to enhance the magnetic field strength. This feature may have an advantage in an e^+e^- linear collider application where an overall small magnet but a strong magnetic field gradient is needed.

The Final Focus system of a linear collider needs a quadrupole with variable focal strength. Rotation of PMQ sections divided along the beam axis can change the focal strength, but maybe at the expense of field quality. So we fabricated a PMQ with a “double ring structure”, which can ease the errors in field quality caused by changing strength.

The double ring structured PMQ has inner and outer rings of NEOMAX; the outer ring is subdivided along its length and each section can rotate. By rotating different lengths one can vary the integrated strength in small steps. Because of the fixed inner ring and tight mechanical tolerances, the sensitivities of the magnetic center and pole angles to the rotation of the outer rings are largely suppressed. Magnetic measurements of the PMQ are given.

This research was partially supported by the Ministry of Education, Science, Sports and Culture, Grant-in-Aid for Scientific Research (A), 14204023, 2002 and the U.S. Department of Energy under contract number DE-AC02-76SF00515.

T. Mihara and Y. Iwashita are with Kyoto University, Gokasho Uji, Kyoto, 611-0011 JAPAN (e-mail: mihara@kyticr.kuicr.kyoto-u.ac.jp, iwashita@kyticr.kuicr.kyoto-u.ac.jp).

M. Kumada, is with National Institution of Radiological Sciences, 4-9-1, Anagawa, Inage-ku, Chiba-shi, 263-8555 JAPAN (e-mail: amc-kumada@cocoa.plala.or.jp).

C. M. Spencer is with Stanford Linear Accelerator Center, 2575 Sand Hill Road; Menlo Park CA 94025 (e-mail: Cherrill@slac.stanford.edu).

II. PERMANENT VARIABLE-STRENGTH QUADRUPOLE

We have constructed a variable-strength permanent magnet quadrupole as a candidate for the final focus (FF) quadrupole in a linear collider. The PMQ is composed of an inner ring and four outer rings. (See Fig. 1 and Table I for its parameters.)

Only the outer rings are rotated in order to change the integrated gradient. The fixed inner ring suppresses any errors caused by rotation of outer rings [1]. Outer rings are rotated just 90° to switch the phase of that section’s quadrupole (from focus to defocus and vice versa. See Table II). Therefore, this PMQ with four outer rings can produce a series of 16 integrated gradients from 3.47T to 24.2 T in 1.4 T steps. Integrated gradient is proportional to “Switched on” length (SWL), the sum of outer ring lengths that are in the “strong” phase [3].

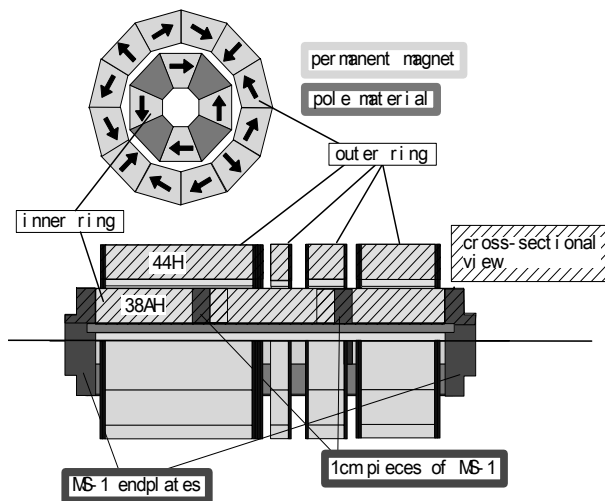

Fig. 1. Diagram of the adjustable PMQ as it is fabricated

TABLE I
SCALE AND PERFORMANCE OF THE PMQ

Bore radius	1cm
Inner ring radii	Inner 1 cm, outer 3 cm
Outer ring radii	Inner 3.3 cm, outer 5 cm
Outer ring section lengths	1 cm, 2 cm, 4 cm, 8 cm
Physical length	23 cm
Pole material	Permendur
Magnet material(inner ring)	NEOMAX38AH
Magnet material(outer ring)	NEOMAX44H
Integrated gradient(strongest)	24.2 T (115 T/m)
Integrated gradient(weakest)	3.47 T (16.5 T/m)
Int. gradient step size	1.4 T (6.7 T/m)

TABLE II

THE 16 CASES OF POSITIONS OF THE OUTER RING

No.	8cm	4cm	2cm	1cm	No.	8cm	4cm	2cm	1cm
1	On	On	On	On	9	Off	On	On	On
2	On	On	On	Off	10	Off	On	On	Off
3	On	On	Off	On	11	Off	On	Off	On
4	On	On	Off	Off	12	Off	On	Off	Off
5	On	Off	On	On	13	Off	Off	On	On
6	On	Off	On	Off	14	Off	Off	On	Off
7	On	Off	Off	On	15	Off	Off	Off	On
8	On	Off	Off	Off	16	Off	Off	Off	Off

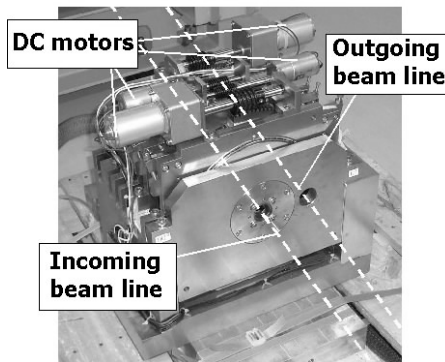

Fig. 2. The second prototype PMQ.

A. PMQ structure and rotation mechanism

Fig. 3 shows the inner ring structure. This is supported by Vanadium Permendur poles and MS-1, a thermal compensation material. Magnet pieces are attached to the Permendur with glue. The inner ring is directly supported by stainless steel (SS) end plates that are fixed on the SS base block. The outer ring of magnets is attached to the inside of a cylindrical ring cover (see fig. 4). The ring cover is inserted in a SS ring support plate, supported by the bearing to be rotated. Each ring cover has a rotating spur gear (4 DC motors with worm gears move the spur gears to rotate the outer rings against a maximum torque of 80 Nm. See Fig. 2). The four plates are fixed to a SS base [1].

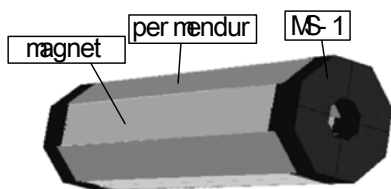

Fig. 3. Inner ring structure: 4 pieces of permendur and 2 pieces of MS-1 support the permanent magnet pieces.

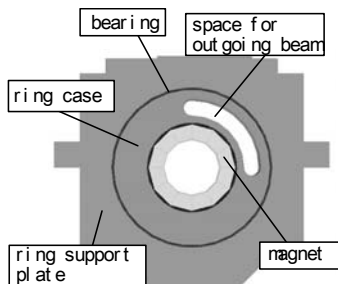

Fig. 4. An outer ring structure.

B. Strength measurement result

Fig. 5 show repeated measurements of integrated strength over several hours in the strongest case and weakest case respectively. Each strength measurement takes about 3 minutes [4]. The strongest and weakest integrated strengths are 24.2 T and 3.47 T, respectively. The discrepancy between the design value and the measured value is about 5% both in the strongest and in the weakest case.

Fig. 5 also shows that the integrated strength of the PMQ changes very slightly with time. These variations are correlated with the temperature of the magnet. The strength of the strongest arrangement changes by about 10^{-4} T in four hours. That in the weakest case fluctuates by about 10^{-3} T over 80 hours of repeated measurements. Fig. 6 shows the measured strength of six cases at various switched-on lengths. The strength is proportional to the cumulative switched-on length, as expected.

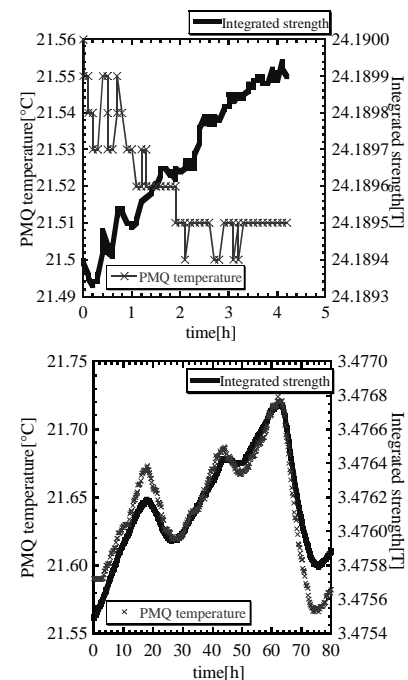

Fig. 5. The integrated strength vs. time. The upper graph shows the strongest case, the lower one the weakest case.

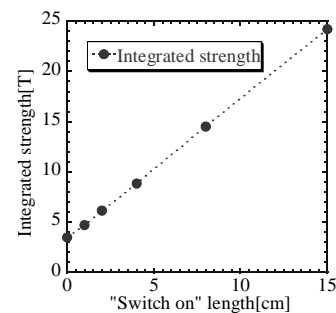

Fig. 6. The variation of integrated strength

III. ADJUSTMENT OF PMQ

A. Pole angle adjustment

It is necessary to precisely adjust the stopping angle of each outer ring because the skew angle of the ILC final focus quadrupole field must be less than a few μrad . The procedure for adjusting the stopping angles, together the results, follow.

The stopper block fixed on the spur gear comes in contact with the stopper lever which is fixed on the ring support plate, then a motor control system detects the overload of the motor and shut the current and the rotation stops. Each stopper is finely adjusted so as to make a deliberate 90° rotation. Therefore, the rotation stop angle of an outer ring is controllable by the stopper lever position, it can be fine-tuned by turning the appropriate thrust screw (see Fig. 7). If the phase of the inner ring's quadrupole equals that of the outer ring, the quadrupole strength should be maximum. We tuned the stopper by turning the screw, checking the integrated strength by a rotating coil measurement system, and searched for the best position.

The angle that gives the maximum or minimum value of the magnetic field is the correct stopping angle (skew=0). For instance, Fig. 8 shows that the phases of the inner ring and the 8 cm outer ring become coincide perfectly when the angle of PMQ is about 43.715° (relative angle to the 1st south pole).

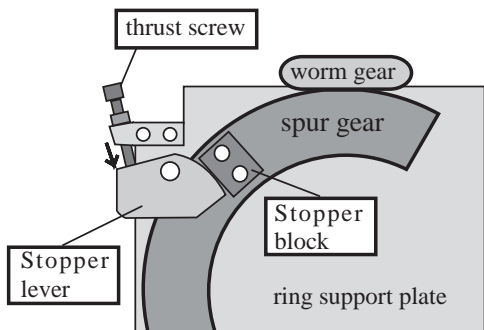

Fig. 7. Gear stopper adjustment stop angle on each side is made by the screw.

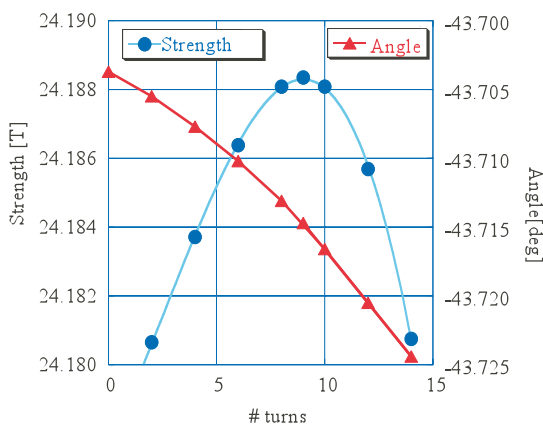

Fig. 8. Angle adjustment of 8 cm outer ring

B. Field quality

The higher multipole components of the PMQ should be within the tolerances of the ILC FF quadrupole, but they have

not been specified yet. The multipole components of the PMQ have been measured at two different strengths (see Fig. 9) by a “double-coil” rotating coil. Because we are not using a bucking coil to do the harmonics measurements, the variations in the quadrupole signal are falsely interpreted as a sextupole signal. The size of the sextupole component in Fig. 9 is an over-estimate of the real sextupole, which we believe is not much more than 1×10^{-3} of the quadrupole. Left graph in Fig. 9 shows multipoles measured at 3.8 mm at 100% and 55% strength, they are almost the same, which is preferred. Right graph in Fig. 9 shows how little the multipole components change when the 8 cm ring is shimmed in order to adjust the magnetic center (see below).

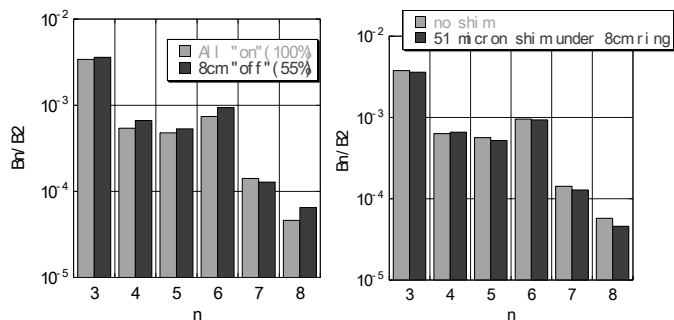

Fig. 9. Measured Multipole Components
Left: 100% strength (all on) & 55% (8 cm off)
Right: 8 cm ring shimmed or not with 8 cm off

C. Magnetic center adjustment

The magnetic center of the PMQ must move less than a few microns when an outer ring is rotated to change its strength for use in the linear collider final focus. When the PMQ was first assembled and measured we observed that its magnetic center position, defined by X and Y coordinates quoted relative to the axis of the rotating measuring coil, moved by several tens of microns when measured at different strengths. (see Fig. 10)

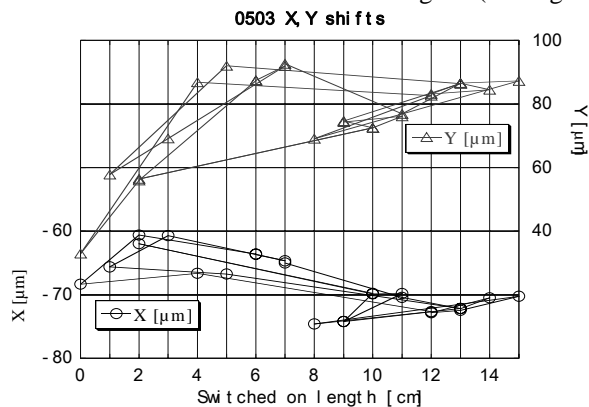

Fig. 10. Center position of PMQ at different strengths. Lines between points show history of measurements.

There are two scenarios that could produce this movement of the center. In the first, the magnetic center axis of an individual outer ring does not coincide with its rotation axes. In the second the rotation axis of an outer ring is shifted from that

of the inner ring. The inner ring is fixed directly to the SS base in our PMQ, and each outer ring is supported by a bearing fitted in that ring's support plate. Each plate with an outer ring is put on the SS base block, and fixed with screws.

It is possible to shift an outer ring by placing a shim between a ring support plate and the SS base block where the outer ring is supported (see Fig.11). We put different thicknesses of shims between the SS base block and the 4 outer ring cases, thus moving each outer ring, one at a time, and measured the movement of the magnetic center.

Shimming can only lift up or move an outer ring in the $-X$ direction, therefore we could not adjust the center in the $-Y$ direction or $+X$ direction. Grinding the SS frame or SS base would make it possible to adjust all outer rings and shift the center in any direction.

Lifting the 8 cm outer ring up by $51\ \mu\text{m}$ reduced the center movement from $30\ \mu\text{m}$ to $10\ \mu\text{m}$ when the strength was changed by about 45% (see Fig. 12 left). Fig. 12 right shows an example of shimming by lifting and horizontal displacement. The 8 cm outer ring is lifted up by $76\ \mu\text{m}$ and the 4 cm outer ring is moved in the negative x direction by $51\ \mu\text{m}$. Then the Y-magnetic center shift when 8 cm ring is rotated becomes $< 5\ \mu\text{m}$ and the X-shift of 4 cm outer ring becomes $< 1\ \mu\text{m}$.

IV. CONCLUSION

The integrated strength of the fabricated variable strength PMQ was 24.2 T and 3.47 T in the strongest and weakest cases respectively. This is within the range of values that were expected from the design calculations.

The field quality of the PMQ is good and it was not affected by changing the integrated strength or by shimming.

The control of the stopping angle was realized by adjusting the stopper. This decreased the overall rotation of the PMQ. One turn of the screw on the 8 cm outer ring stopper adjusts the skew angle by $\sim 20\ \mu\text{r}$ on this PMQ in its strongest configuration.

The magnetic center axes of the outer rings are adjusted by using $25.4\ \mu\text{m}$ shims. The center movement caused by rotation of the 8 cm outer ring was successfully reduced from some tens of microns to $5\ \mu\text{m}$ in the Y direction by lifting it up by $76\ \mu\text{m}$. The required tolerance of the center shifts during beam based alignment is less than a few microns for 20% reduction of the strength. The measured values do not satisfy this but further adjustments would allow this tolerance to be met.

V. FUTURE PLANS

As the shimming worked very well in some cases, an automated shimming mechanism should be incorporated in a future design. In particular, fine adjustments in both polarities are important.

The integrated strength appears to change with time. This phenomenon was also seen in the first prototype measurement. We are preparing a dipole magnet made of NEOMAX35SH and iron, whose strength will be measured for very long time to confirm the time evolution of strength.

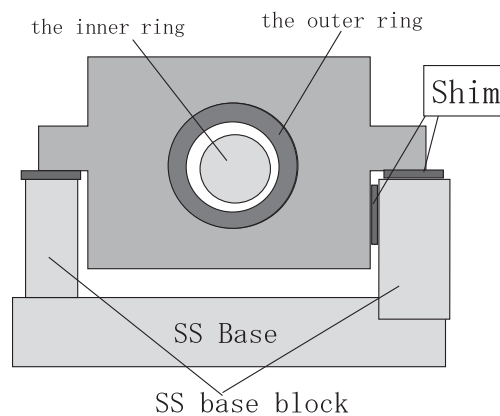

Fig. 11. Sketch of PMQ showing shim placement

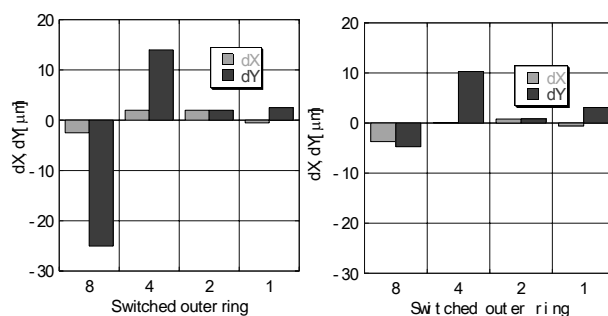

Fig. 12. Center: movement affected by shimming. Left: before shimming. Right: 8 cm ring lifted up by $76\ \mu\text{m}$. "8" refers to the 8 cm long outer ring.

A new inner ring with $\phi 14\ \text{mm}$ bore is now under development to make good use of saturated vanadium permendur. A strength enhanced PMQ is coming soon.

The saturated magnetic flux density of the Fe-Ni alloy MS-1 varies linearly in the vicinity of room temperature, so this material [5] can be used for temperature compensation in the PMQ. The next version of the PMQ, which will have a $\phi 14\ \text{mm}$ bore, will incorporate optimized MS-1 compensation parts for both the inner and outer rings in order to generate thermally stable field at all strengths.

REFERENCES

- [1] T. Mihara, Y. Iwashita, M. Kumada, C. M. Spencer, E. Antokhin, "Super Strong Permanent Magnet Quadrupole for a Linear Collider," *IEEE trans. Appl. Supercond.* Vol.14, No.2, pp 469-472, June 2004.
- [2] K.Halbach, *IEEE, Trans., NS26* (1979), 3882, NIM169 (1989)1 NIM 187(1981)109 NIM 198(1982)213
- [3] M.Kumada et al., patent pending. See *CERN Courier*, volume 41, number 7, September 2001, p.9.
- [4] T. Mihara, Y. Iwashita, M.Kumada, C.M.Spencer "Superstrong Adjustable Permanent Magnet for a Linear Collider Final Focus" 12th Linear Accelerator Conference, Lubeck, Germany, August 16-20, 2004. SLAC-PUB-10878.
- [5] NEOMAX Inc. The catalogue of MS-1 alloy