

(19) World Intellectual Property Organization  
International Bureau



(43) International Publication Date  
18 December 2008 (18.12.2008)

PCT

(10) International Publication Number  
WO 2008/153376 A1

(51) International Patent Classification:  
H02J 3/18 (2006.01) H02M 7/00 (2006.01)

(74) Agent: VAN BREDA, Jacques; 20052, Weteringschans  
96, 1017 XS Amsterdam, NL-1000 HB Amsterdam (NL).

(21) International Application Number:  
PCT/NL2007/050289

(81) Designated States (unless otherwise indicated, for every kind of national protection available): AE, AG, AL, AM, AT, AU, AZ, BA, BB, BG, BH, BR, BW, BY, BZ, CA, CH, CN, CO, CR, CU, CZ, DE, DK, DM, DO, DZ, EC, EE, EG, ES, FI, GB, GD, GE, GH, GM, GT, HN, HR, HU, ID, IL, IN, IS, JP, KE, KG, KM, KN, KP, KR, KZ, LA, LC, LK, LR, LS, LT, LU, LY, MA, MD, MG, MK, MN, MW, MX, MY, MZ, NA, NG, NI, NO, NZ, OM, PG, PH, PL, PT, RO, RS, RU, SC, SD, SE, SG, SK, SL, SM, SV, SY, TJ, TM, TN, TR, TT, TZ, UA, UG, US, UZ, VC, VN, ZA, ZM, ZW.

(22) International Filing Date: 15 June 2007 (15.06.2007)

(25) Filing Language: English

(26) Publication Language: English

(71) Applicant (for all designated States except US): TECHNISCHE UNIVERSITEIT DELFT [NL/NL]; Stevinweg 1, NL-2628 CN Delft (NL).

(84) Designated States (unless otherwise indicated, for every kind of regional protection available): ARIPO (BW, GH, GM, KE, LS, MW, MZ, NA, SD, SL, SZ, TZ, UG, ZM, ZW), Eurasian (AM, AZ, BY, KG, KZ, MD, RU, TJ, TM), European (AT, BE, BG, CH, CY, CZ, DE, DK, EE, ES, FI, FR, GB, GR, HU, IE, IS, IT, LT, LU, LV, MC, MT, NL, PL, PT, RO, SE, SI, SK, TR), OAPI (BF, BJ, CF, CG, CI, CM, GA, GN, GQ, GW, ML, MR, NE, SN, TD, TG).

(72) Inventors; and

(75) Inventors/Applicants (for US only): FERREIRA, Johannes Abraham [ZA/NL]; Wethouder Verheulplantsoen 6, NL-2497 BS Den Haag (NL). YUAN, Zhihui [CN/NL]; Karel Doormanlaan 292, NL-2283 BC Rijswijk (NL). DE HAAN, Sjoerd Walter Hero [NL/NL]; Zaaihoek 32, NL-2614 WX Delft (NL).

Published:  
— with international search report

(54) Title: POWER FLOW CONTROLLER

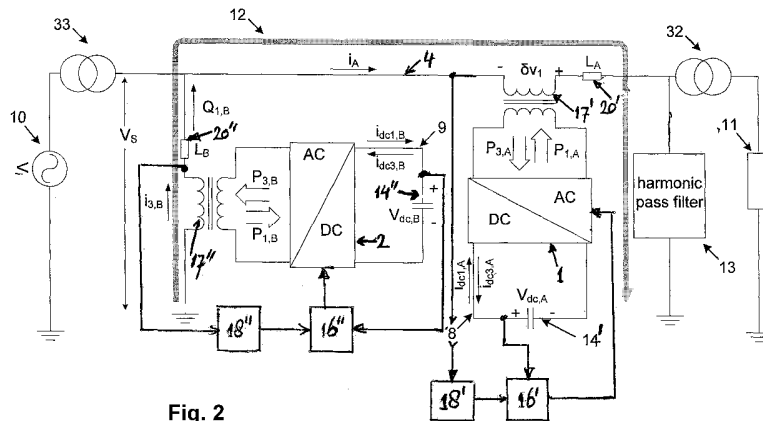

Fig. 2

(57) Abstract: The invention relates to a power flow controller, comprising at least one first converter coupled with a power transmission line, and at least one second converter coupled with a power source, wherein said power source operates at a predetermined first frequency and connects to the power transmission line, said controller further comprising means for exchanging power between the first converter and the second converter, wherein the transmission line forms part of the only means for exchanging power between the first converter and the second converter, wherein the first converter and the second converter each have a power storage device, and wherein the second converter is arranged to continuously feed the power transmission line with power at a second frequency which is a higher harmonic of the power source's first frequency, for transferring power from the second converter to the first converter.

WO 2008/153376 A1

## Power flow controller

The invention relates to a power flow controller comprising at least one first converter coupled with at least one power transmission line, and at least one second converter coupled with a power source, wherein said power source operates at a predetermined first frequency and connects to the power transmission line, said controller further comprising means for exchanging power between the first converter and the second converter.

Such a power flow controller is known from US-A-5,343,139.

The known power flow controller is shown in the simplified diagram that is provided in Fig. 1 hereof, and the operation of this known power flow controller can be clarified as follows.

Fig. 1 shows a prior art unified power controller (UPFC) comprising a converter 1 connected in series with the transmission line 4 and a converter 2 connected in shunt with the transmission line 4. Converter 1 is used to generate a voltage  $\delta v$ , on winding 3, of controllable amplitude and phase that is added to the system voltage of the transmission line 4. The injected voltage  $\delta V$  is used for voltage control and power flow control by phase control of the transmission line 4. Converter 2 serves as power source for converter 1, and in addition it is also used to inject reactive power  $Q$  in the transmission line 4. The power balance between the two converters is achieved by regulating the voltage on the dc bus capacitor 7. The current  $i_{dc,A}$  in line 5, that converter 1 draws is determined by the power requirement for establishing  $\delta V$ . The current  $i_{dc,B}$  in line 6, that converter 2 feeds into the capacitor 7, is controlled to maintain the dc bus capacitor voltage at a preset level. This implies that current  $i_{dc,B}$  of converter 2 has the same average value as current  $i_{dc,A}$  of converter 1.

The known power flow controller has had limited impact because of the high cost and low reliability. The relative high cost is mainly due to the high voltage insulation requirements (up to 400kV), fault protection and the low production numbers.

The invention has as objective to resolve these problems of the prior art and to provide an alternative solution in which the high voltage installation requirements can be relaxed.

To this end the power flow controller of the invention is characterized by one or more of the appended claims.

In a first aspect of the invention the transmission line forms part of the only means for exchanging power between  
5 the first converter and the second converter, that the first converter and the second converter each have a power storage device, and that the second converter is arranged to continuously feed the power transmission line with power at a second frequency which is a higher harmonic of the power source's first  
10 frequency, for transferring power from the second converter to the first converter.

In a second aspect a current loop for the power at the second frequency is arranged.

By these measures the power flow controller of the invention provides transmission of power from the second converter  
15 to the first converter while the second converter can electrically float at line potential. Due thereto provisions for high voltage insulation can be dispensed with for the second converter. The second converter can act as a generator of a relatively small harmonic voltage causing a corresponding current in  
20 the power transmission line that flows to the first converter that in turn generates a corresponding harmonic voltage at its terminals, in order to extract the required amount of power for storage in its power storage device and conversion into the required power of the first frequency.  
25

An effective and adequate manner of construing the power flow controller of the invention is characterized in that the first converter and the second converter each are of the type AC/DC converter and that the power storage devices of said  
30 converters are capacitors at the converter's DC/sides.

In order to effect that effectively the first converter and the second converter are operated at a balanced energy level in respect of their respective power storage devices, it is preferable that the first converter and the second converter are  
35 connected to a dedicated first respectively second waveform-controller so as to shape the power converted by said converters depending on at least a desired predetermined level of energy in the respective power storage devices of said converters.

In order to promote that the power flow controller of the invention adequately operates at all circumstances, it is  
40 further preferable that each waveform controller is connected to and operates depending on a dedicated power-controller, the con-

trol actions of which are derived from predetermined electrical parameters, viz. for the power controller of the first converter: the power consumption of a load connected to the power transmission line, and for the power controller of the second  
5 converter: the power provided at the exit side of said second converter.

It is further desirable that a pass-filter for said higher harmonic second frequency is connected to the power transmission line, for instance at the side of the load. This  
10 arranges for a suitable current loop for the harmonic frequency power that the second converter induces into the power transmission line.

In still a further aspect of the invention it is proposed that a number of first converters and/or a number of second  
15 converters are placed in series. In this manner it is possible to apply relatively small converters which is cost-effective, and to simultaneously increase reliability because the higher number of converters introduces redundancy.

Hereinafter the invention shall be further elucidated  
20 with reference to a non-limiting example and with reference to the drawing showing in:

- Fig. 1 a schematic diagram of a prior art power flow controller;
- Fig. 2 a schematic diagram of a power flow controller  
25 in accordance with a first embodiment according to the invention;
- Fig. 3 some exemplary time domain waveforms occurring in the power flow controller of the invention;
- Fig. 4 a schematic diagram of a converter circuit together with its waveform controller and power controller;  
30
- Fig. 5 a schematic diagram of a second embodiment of a power flow controller according to the invention;
- Fig. 6 a schematic diagram of a third embodiment of a power flow controller according to the invention;
- Fig. 7 shows a schematic diagram of a fourth embodiment of a power flow controller according to the invention.  
35

Fig. 1 shows the prior art power flow controller and has been discussed hereinabove.

Fig. 2 shows a simplified circuit diagram wherein the  
40 first converter 1 and the second converter 2 are shown to be disconnected from each other. The first converter 1 is coupled in series with the power transmission line 4, whereas the second

converter 2 is coupled parallel with a power source 10. The current balance to stabilize the voltage on the capacitors of said converters 1,2 is achieved by generating two current components. A first component,  $i_{dc1,A}$ , and  $i_{dc1,B}$  at lines 8 and 9, respectively, is generated by the power flowing through both converters 1,2 at a predetermined fundamental frequency of the power source 33. The second component,  $i_{dc3,A}$  (line 8) and  $i_{dc3,B}$  (line 9) relates to power at a harmonic frequency. In this embodiment it concerns the 3<sup>rd</sup> harmonic, but the principle is also applicable to other harmonic frequencies. The fundamental power flows through the power transmission line 4 running from the sourcing part of the grid 10 to the load part of the grid 11. The power and the current at the harmonic frequency flow through a local loop 12. A harmonic pass filter, 13, is added to the power transmission line 4 to close the current loop for this third harmonic current. In a three-phase system this third harmonic voltages in each of the phases are generated with the same phase to avoid circulating currents.

The first converter 1 and the second converter 2 each are of the type AC/DC converter as Fig. 2 shows, and the figure shows further that the power storage devices 14', 14'' are capacitors at the converters' DC-sides.

Fig. 2 and Fig. 4 further show that the first converter 1 and the second converter 2 are connected to a dedicated first (16') respectively second (16'') waveform controller so as to shape the power converted by converters 1 and 2, depending on at least a desired predetermined level of energy in the respective power storage devices 14', 14'' of said converters 1,2.

Also each waveform controller 16', 16'' is connected to and operates depending on a dedicated power controller 18', 18'', the control actions of which are derived from predetermined electrical parameters viz. for the power controller 18' for the first controller 1: by the power consumption of a load 11 connected to the power transmission line 4, and

for the power controller 18'' of the second converter 2: by the power provided at the exit side of said second converter 2. A further detailed explanation shall be offered hereinafter in relation to Fig. 4.

Fig. 4 shows schematically the power electronic circuit commonly devised for and separately applied to both converter 1 and converter 2. Switching devices in the form of insulated gate bipolar transistors (IGBT) 15 or similar power semiconductors

are switched with pulse width modulation control 16', 16'' to generate a voltage,  $e$ , on transformer winding 17', 17''. The control reference is generated by an external power controller 18', 18''. The measurements and references, 19, depend on the configuration and parameters of the grid, and are as discussed above with reference to Fig. 2. The voltage,  $e$ , is a pulse width modulated square wave and is filtered by the inductance  $L$ , 20', 20''. The inductance  $L$  could be from an inductor or from the leakage inductance of the transformer. The terminals, 21, 22 are connected to the grid. Each converter 1,2 contains its own capacitor 14', 14'' to provide a stable dc voltage. The voltage is stabilized by controlling the two current components,  $i_{dc,1}$  and  $i_{dc,3}$  in lines 8 and 9 respectively, so that they have the same average value.

For the purpose of illustration reference will now be made to Fig. 3. Fig. 3 illustrates an example of the voltage and current waveforms in the system of Fig. 2 with the active power exchange between converter 1 and 2 at harmonic frequency according to the invention. Assume that, for reasons of power control,  $\delta V_1$  is the voltage that converter 1 injects into grid at the fundamental frequency, and that  $I_1$  is the current that is flowing at the fundamental frequency (Fig. 3a). The voltage  $\delta V_1$  is the fundamental component of the voltage  $\delta V,3$ . The resulting power injected to grid at the fundamental frequency is  $P_{1A}$  (Fig. 3b). To compensate the power  $P_{1A}$  that is extracted from the capacitor 14' a power which has the same mean value should be absorbed by converter 1 at a different frequency, for instance the 3<sup>rd</sup> harmonic. For the case of a third harmonic  $V_{3A}$  and  $I_3$  are the third harmonic voltage and corresponding third harmonic current at the ac terminals of converter 1 (Fig. 3c). Neglecting losses, the mean value of power in the 3<sup>rd</sup> harmonic frequency  $P_{3A}$  should be equal to the power at the fundamental frequency  $P_{1A}$ . The power  $P_{3A}$  that is absorbed by converter 1 is generated by converter 2 acting as a source of the third harmonic. The voltage generated by converter 1 is the sum of  $\delta V,1$  and  $V_{3A}$ , (Fig. 3d). The associated combined power  $P_{1A} + P_{3A}$  has a zero mean value.

Turning now to Fig. 5 a very schematic diagram is shown of a second embodiment of a power flow controller according to the invention.

The power flow controller of Fig. 5 differentiates from the power flow controller according to a first embodiment shown in Fig. 2 in that the first converter 1 and the second converter

2 are placed in series with the power transmission line 4.

Again, also in this embodiment there is provision for a current loop 30 to transfer the power that the second converter 2 generates at the second frequency in order to allow same to arrive at the first converter 1. Note in this connection that provision is made for suitable pass filters 13 to close the current loop 30.

Reference is now made to Fig. 6 showing schematically a third embodiment of the power flow controller of the invention showing as an example that both a number of first converters 1, 1', 1'' can be placed in series and/or a number of second converters 2, 2', 2'' can be placed in series. In this manner for both the first converters 1, 1', 1'' and the second converters 2, 2', 2'' the reliability of the system can be improved due to the redundancy that is introduced into the system. When one of the first converters or one of the second converters fails, then the task of the failing converters is assumed by the remaining converters.

Fig. 7 shows a fourth embodiment of the power flow controller of the invention. In the schematic diagram shown it concerns a three-phase system having at the side of the power supply 10 a delta-ye transformer 33 and at the side of the load 11 a ye-delta transformer 32.

As in the embodiment shown in Fig. 6 each line of the three-phase system of Fig. 7 is provided with a series of first converters 1, 1' and 1''.

The second converter 2 is connected to the starpoint of the transformer 33 and provides power to the first converters 1, 1' and 1'' at the second frequency which is a higher harmonic of the power source's first frequency.

Differently from the other embodiments shown and discussed here above the second converter 2 of the embodiment shown in Fig. 7 receives its power from a third converter 22 which provides an intermediate connection to the power source 10.

Finally, it is remarked that neither of the Figs. 5, 6 and 7 show the waveform controller 16', 16'' and the power controller 18', 18'' as shown in Fig. 2. Similar waveform controllers and power controllers are however to be applied in connection with the converters shown in the embodiments of Fig. 5, 6 and 7 consistent with the embodiment shown in Fig. 2.

CLAIMS

1. Power flow controller, comprising at least one first converter (1) coupled with a power transmission line (4), and at least one second converter (2) coupled with a power source (10),  
5 wherein said power source (10) operates at a predetermined first frequency and connects to the power transmission line (4), said controller further comprising means (4) for exchanging power between the first converter (1) and the second converter (2),  
**characterized** in that the transmission line (4) forms part of  
10 the only means for exchanging power between the first converter (1) and the second converter (2), that the first converter (1) and the second converter (2) each have a power storage device (14', 14''), and that the second converter (2) is arranged to continuously feed the power transmission line (4) with power at  
15 a second frequency which is a higher harmonic of the power source's first frequency, for transferring power from the second converter (2) to the first converter (1).

2. Power flow controller according to claim 1, wherein the first converter (1) and the second converter (2) each are of  
20 the type AC/DC converter, and that the power storage devices (14', 14'') of said converters (1, 2) are capacitors at the converter's DC-sides.

3. Power flow controller according to claim 1 or 2, wherein the first converter (1) and the second converter (2) are  
25 connected to a dedicated first (16') respectively second (16'') waveform controller so as to shape the power converted by said converters (1,2) depending on at least a desired predetermined level of energy in the respective power storage devices (14',14'') of said converters (1,2).

30 4. Power flow controller according to claim 3, wherein each waveform controller (16',16'') is connected to and operates depending on a dedicated power-controller (18', 18''), the control actions of which are derived from predetermined electrical parameters, viz. for the power controller (18') of the first  
35 converter (1): the power consumption of a load (1) connected to the power transmission line (4), and for the power controller (18'') of the second converter (2): the power provided at the exit side of said second converter (2).

40 5. Power flow controller according to any one of claims 1-4, wherein at least one pass-filter (13) for said higher har-

monic second frequency is connected to the power transmission line (4).

6. Power flow controller according to anyone of claims 1-5, wherein a number of first converters (1, 1', 1'') and/or a  
5 number of second converters (2, 2', 2'') are placed in series.

7. Power flow controller according to any one of claims 1-6, wherein the second converter (2) connects with the power source (10) via a third converter (22).

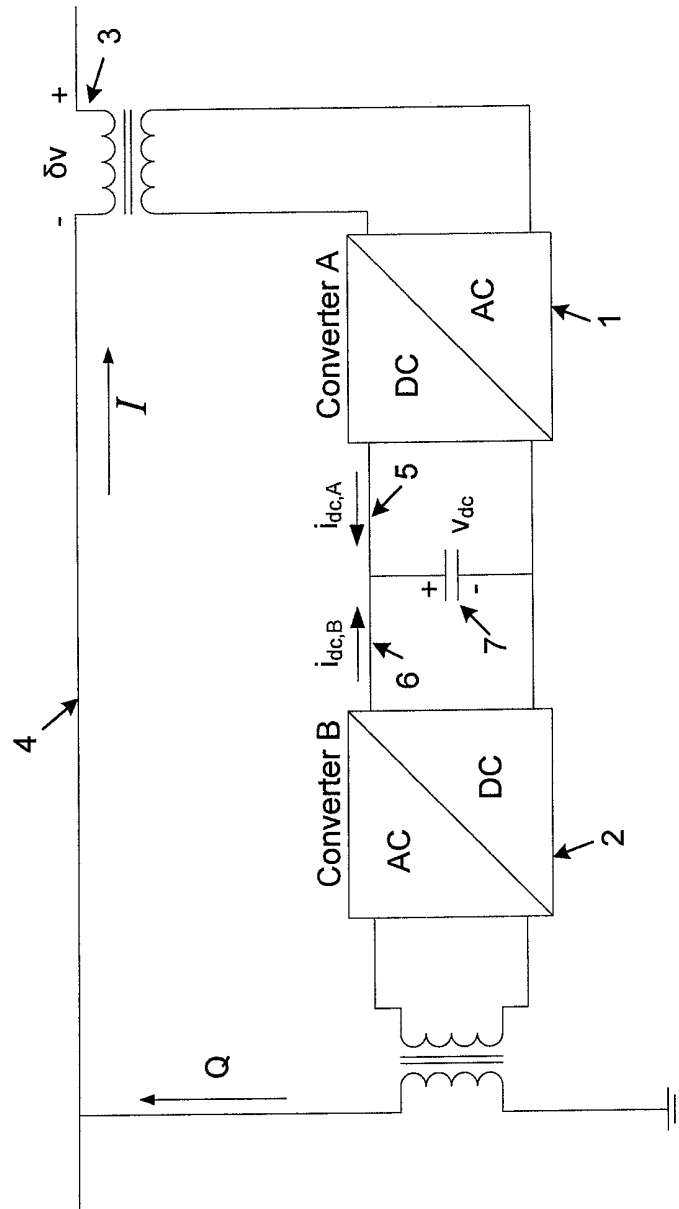

Fig .1

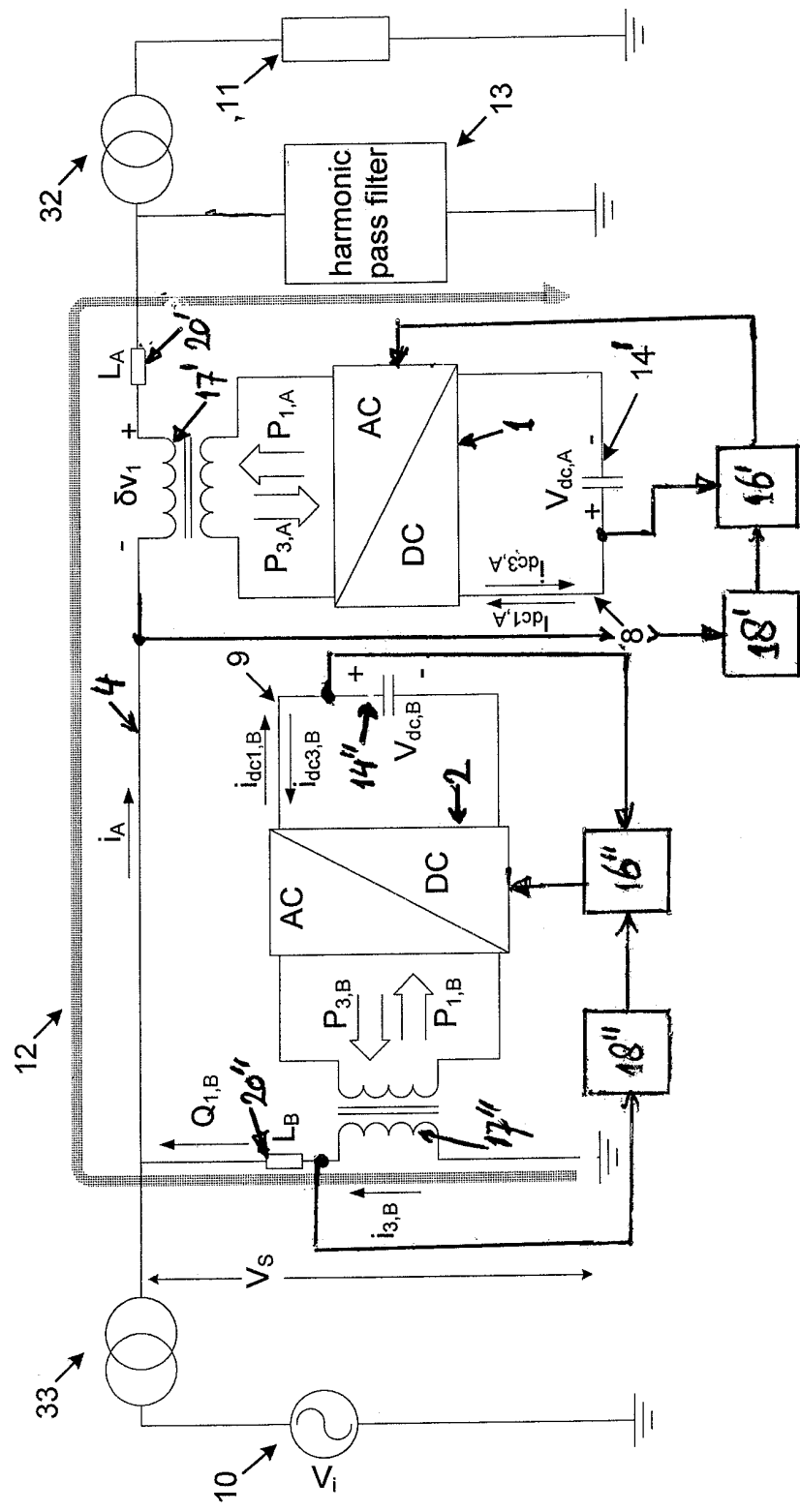
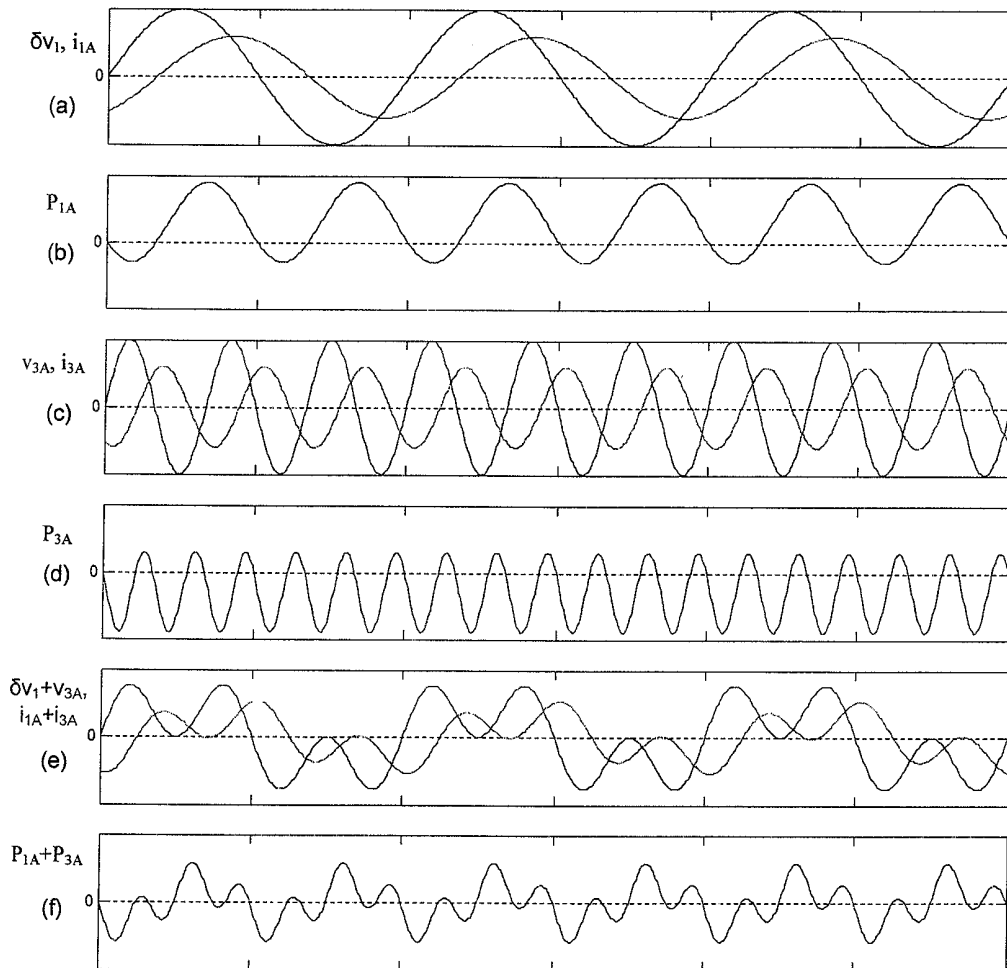

Fig. 2



**Fig. 3**

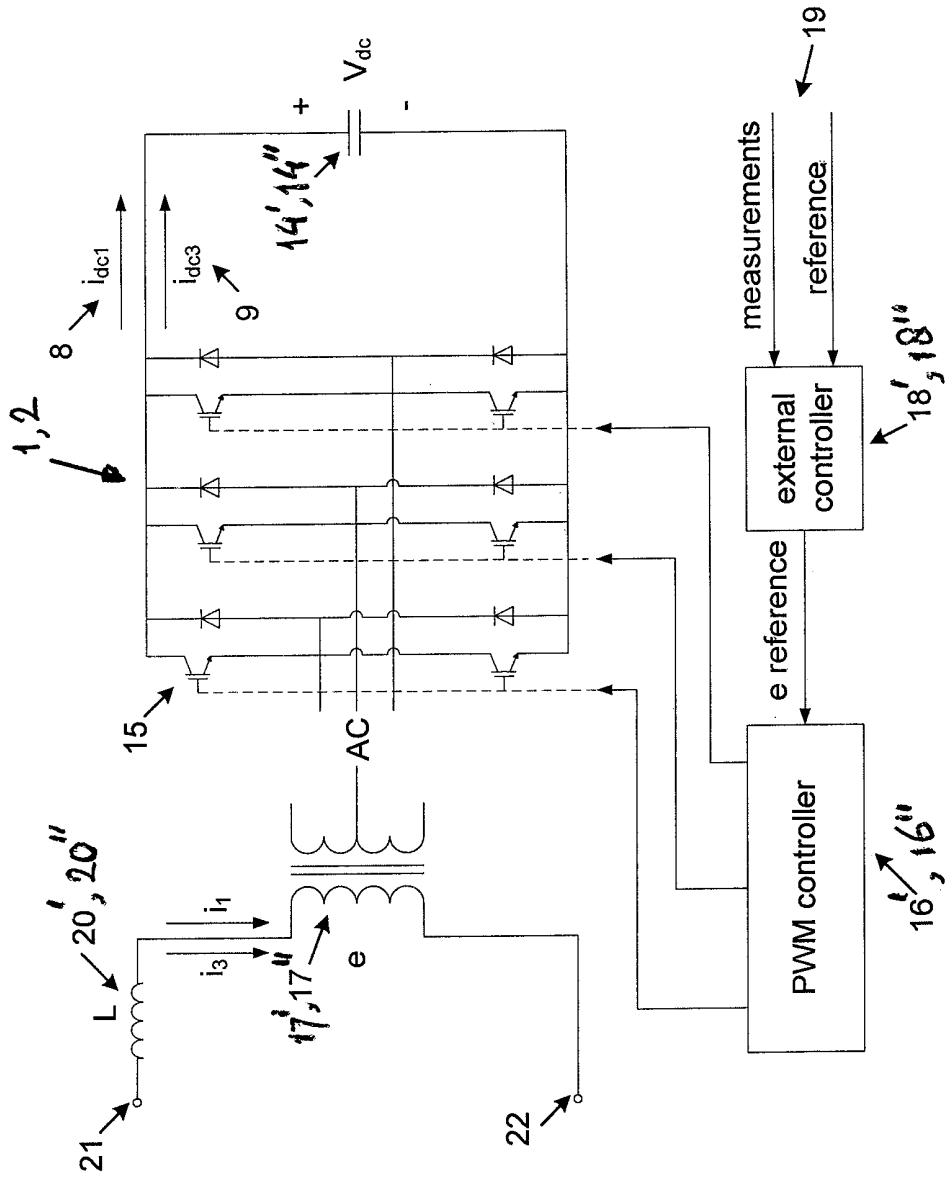

Fig. 4

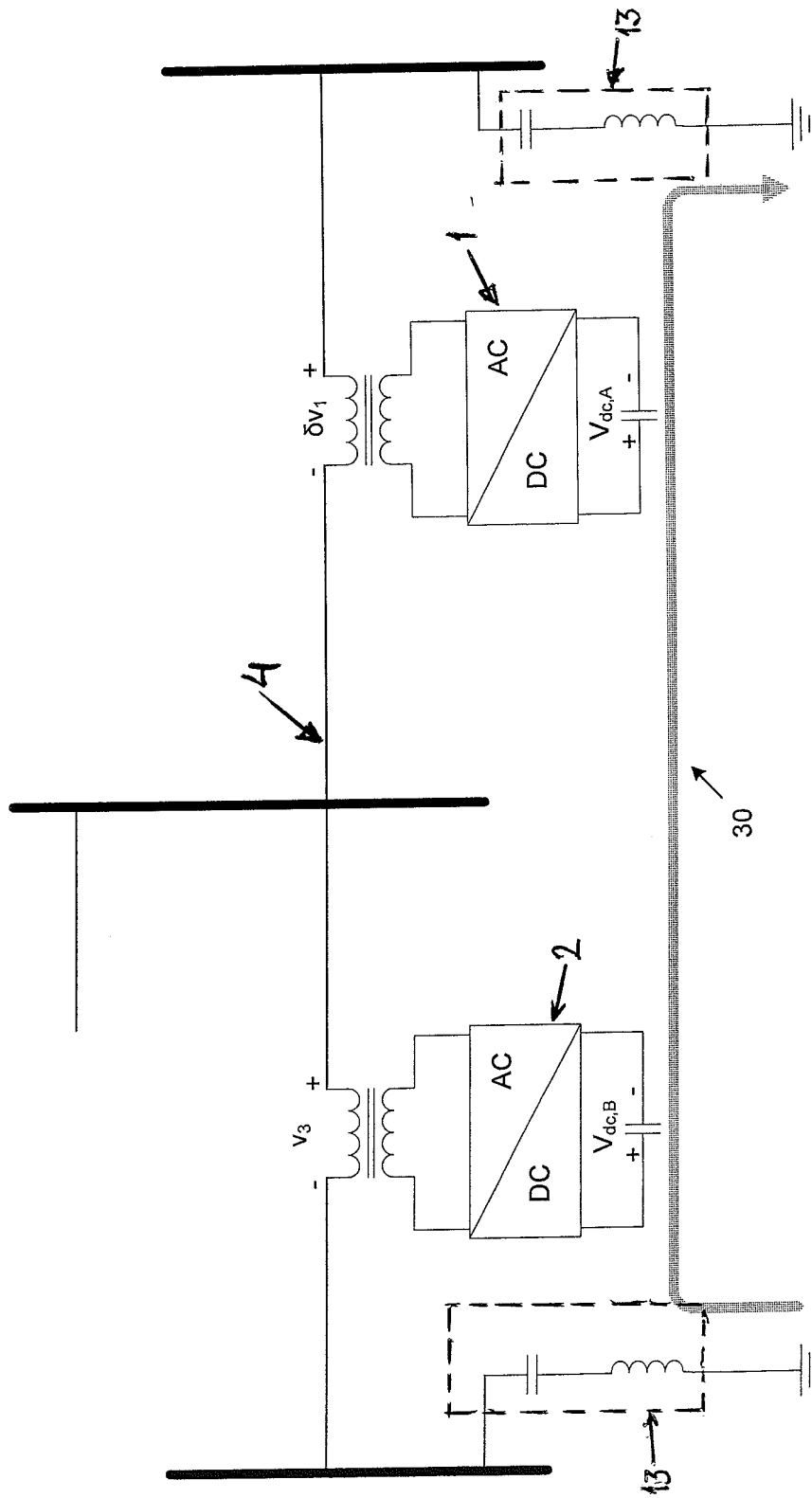

Fig. 5

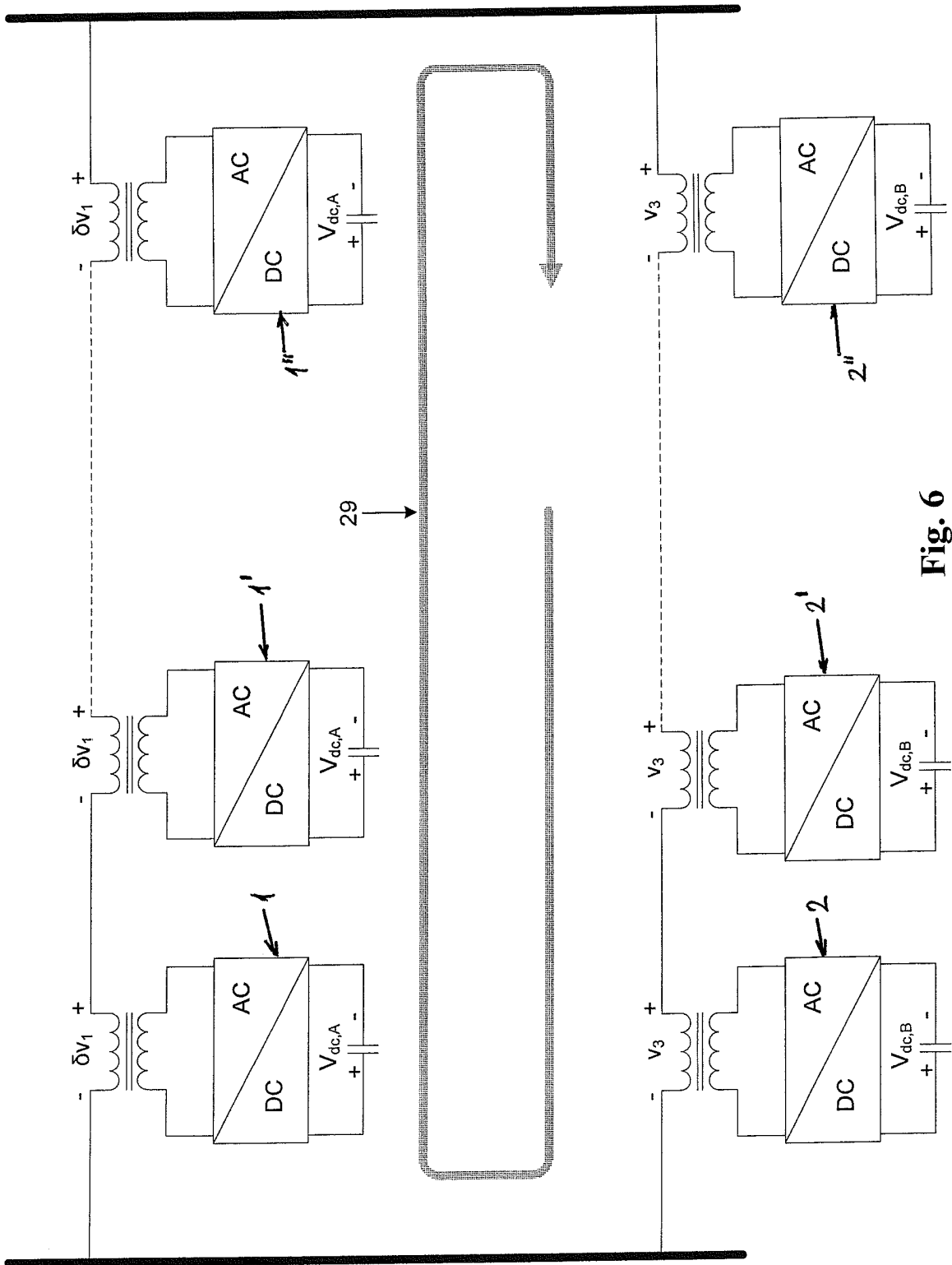

Fig. 6

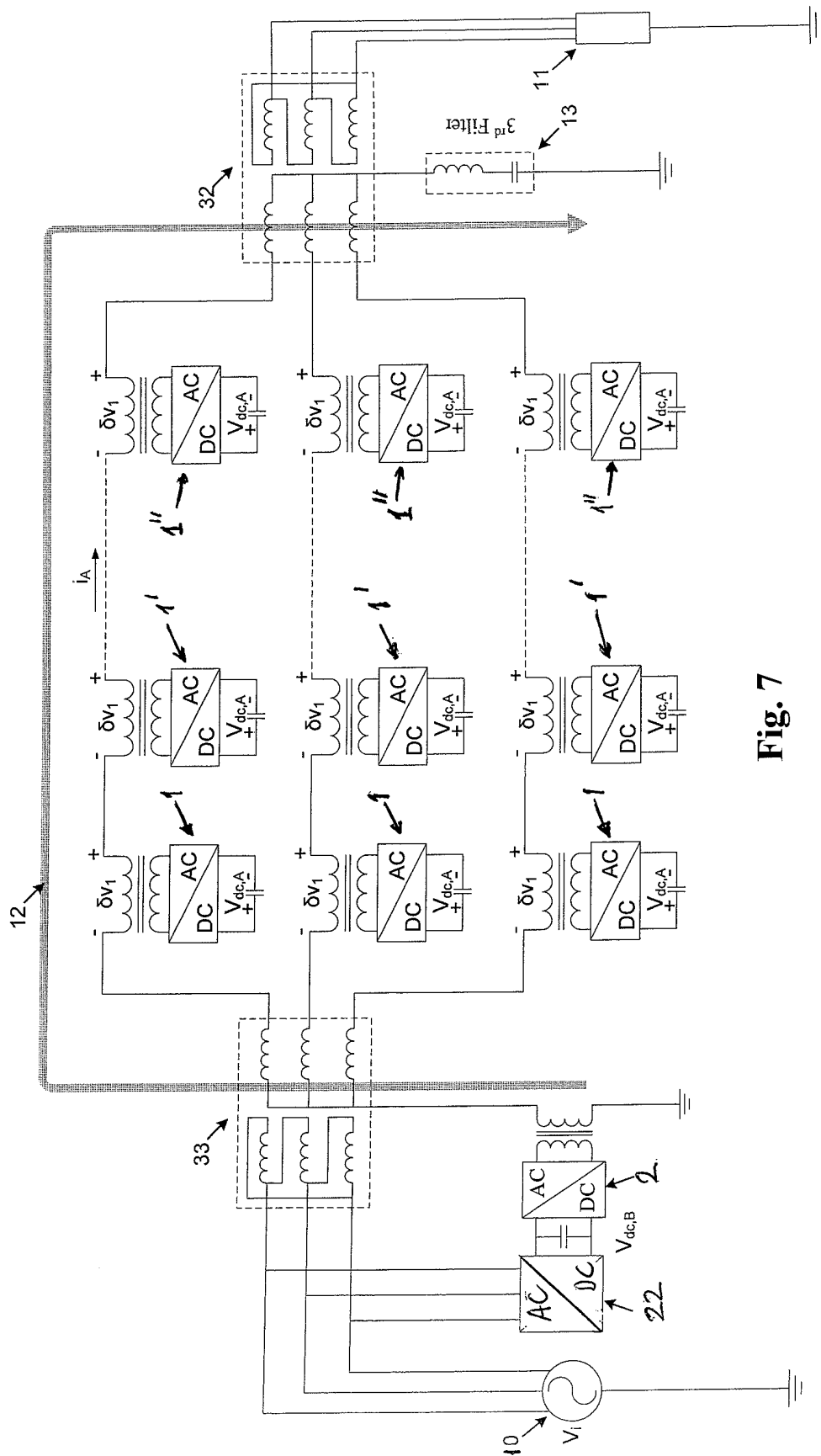

Fig. 7

**INTERNATIONAL SEARCH REPORT**

International application No  
**PCT/NL2007/050289**

**A. CLASSIFICATION OF SUBJECT MATTER**

INV. H02J3/18  
ADD. H02M7/00

According to International Patent Classification (IPC) or to both national classification and IPC

**B. FIELDS SEARCHED**

Minimum documentation searched (classification system followed by classification symbols)

H02J H02M

Documentation searched other than minimum documentation to the extent that such documents are included in the fields searched

Electronic data base consulted during the international search (name of data base and; where practical, search terms used)

EPO-Internal

**C. DOCUMENTS CONSIDERED TO BE RELEVANT**

Category*	Citation of document, with indication, where appropriate, of the relevant passages	Relevant to claim No.
A	JIN WANG ET AL: "A novel configuration of unified power flow controller" APEC 2003. 18TH. ANNUAL IEEE APPLIED POWER ELECTRONICS CONFERENCE AND EXPOSITION. MIAMI BEACH, FL, FEB. 9 - 13, 2003, ANNUAL APPLIED POWER ELECTRONICS CONFERENCE, NEW YORK, NY : IEEE, US, vol. VOL. 1 OF 2. CONF. 18, 9 February 2003 (2003-02-09), pages 919-924, XP010631622 ISBN: 0-7803-7768-0 page 919 - page 920; figures 1,3	1
A	US 5 751 138 A (VENKATA SUBRAHMANYAM S [US] ET AL) 12 May 1998 (1998-05-12) column 6, line 47 - column 8, line 24; figures 3A,3B,4A,5	1



Further documents are listed in the continuation of Box C.



See patent family annex.

\* Special categories of cited documents :

- \*A\* document defining the general state of the art which is not considered to be of particular relevance
- \*E\* earlier document but published on or after the international filing date
- \*L\* document which may throw doubts on priority claim(s) or which is cited to establish the publication date of another citation or other special reason (as specified)
- \*O\* document referring to an oral disclosure, use, exhibition or other means
- \*P\* document published prior to the international filing date but later than the priority date claimed

- \*T\* later document published after the international filing date or priority date and not in conflict with the application but cited to understand the principle or theory underlying the invention
- \*X\* document of particular relevance; the claimed invention cannot be considered novel or cannot be considered to involve an inventive step when the document is taken alone
- \*Y\* document of particular relevance; the claimed invention cannot be considered to involve an inventive step when the document is combined with one or more other such documents, such combination being obvious to a person skilled in the art.
- \*&\* document member of the same patent family

Date of the actual completion of the international search

19 March 2008

Date of mailing of the international search report

03/04/2008

Name and mailing address of the ISA/

European Patent Office, P.B. 5818 Patentlaan 2,  
NL - 2280 HV Rijswijk  
Tel. (+31-70) 340-2040, Tx. 31 651 epo nl,  
Fax: (+31-70) 340-3016.

Authorized officer

Zeng, Wenyan

INTERNATIONAL SEARCH REPORT

International application No  
PCT/NL2007/050289

C(Continuation). DOCUMENTS CONSIDERED TO BE RELEVANT

Category*	Citation of document, with indication, where appropriate, of the relevant passages	Relevant to claim No.
P,X	<p>ZHIHUI YUAN ET AL: "UPFC with Eliminated Common DC Link Connection Between Shunt and Series Part" POWER ENGINEERING SOCIETY GENERAL MEETING, 2007. IEEE, IEEE, PI, June 2007 (2007-06), pages 1-4, XP031118321 ISBN: 1-4244-1296-X page 1, left-hand column - page 2, left-hand column; figures 1,2</p>	1,2,5
A	<p>US 5 343 139 A (GYUGYI LASZLO [US] ET AL) 30 August 1994 (1994-08-30) cited in the application abstract; figure 1</p>	1

# INTERNATIONAL SEARCH REPORT

Information on patent family members

International application No

PCT/NL2007/050289

Patent document cited in search report	Publication date	Patent family member(s)	Publication date
US 5751138	A	12-05-1998	NONE
US 5343139	A	30-08-1994	AU 7561194 A 07-03-1996 WO 9605642 A1 22-02-1996