



Life cycle analysis: A critique

Robert U. Ayres

CMER, INSEAD, Blvd. de Constance, 77305 Fontainebleau Cedex, France

Abstract

Life cycle analysis (LCA) is an increasingly important tool for environmental policy, and even for industry. Analysts are also interested in forecasting future materials/energy fluxes on regional and global scales, as a function of various economic growth and regulatory scenarios. A fundamental tenet of LCA is that every material product must eventually become a waste. To choose the 'greener' of two products or policies it is necessary to take into account its environmental impacts from 'cradle to grave'. This includes not only indirect inputs to the production process, and associated wastes and emissions, but also the future (downstream) fate of a product. The first stage in the analysis is quantitative comparisons of materials flows and transformations. Energy fluxes are important insofar as they involve materials (e.g., fuels, combustion products). This can be an extremely valuable exercise, if done carefully. However, the data required to accomplish this first step are not normally available from published sources. Theoretical process descriptions from open sources may not correspond to actual practice. Moreover, so-called 'confidential' data are unverifiable (by definition) and may well be erroneous. In the absence of a formal materials balance accounting system, such errors may not be detected. A key thesis of this paper is that process data can, in many cases, be synthesized, using models based on the laws of thermodynamics and chemistry. While synthetic but possible data may not fully reflect the actual situation, it is far superior to 'impossible' data. Most of the recent literature on LCA focusses on the second stage of the analysis, namely the selection and evaluation of different, non-comparable environmental impacts ('chalk vs. cheese'). This problem is, indeed, very difficult –and may well be impossible to solve convincingly –even at the conceptual level. However, the only approach that can make progress is one that utilizes monetization to the limits of its applicability, rather than one that seeks to by-pass (or 're-invent') economics. Nevertheless, the evaluation problem is second in priority, for the simple reason that LCA has utility even if the evaluation technique is imperfect. On the other hand, LCA has no (or even negative) utility if the underlying physical data is wrong with respect to critical pollutants.

Keywords: Life cycle analysis; Material product; Environmental impact; Energy input; Waste emission

1. Background: life cycle analysis (LCA)

Life cycle analysis, as the name implies, is an apparently straightforward methodology for assessing all the environmental impacts of a product (or service), from 'cradle to grave',

i.e., from the initial extraction and processing of raw materials to final disposal. The exact definition is the subject of some controversy, and has been the subject of several recent workshops and studies (e.g., [1–4]). The SETAC 'Code of Practice' now divides LCA into four components¹. The first is scoping. The second is taken to be the compilation of quantitative data on both direct and indirect materials/energy inputs and waste emissions, both in production and disposal of a product or service. This phase of the analysis is known as the 'inventory'. The third phase, impact assessment (sometimes called 'eco-profile analysis' (e.g., [5]), includes classification of effects, characterization and valuation. The fourth phase is improvement assessment, which is analysis of implications for purposes of prioritization and assessment of policy alternatives.

An important precursor of LCA was 'net energy analysis', a fairly hot topic during the 1970s. Studies of indirect energy consumption have a fairly long history. One of the first such studies was published in 1969 [6]. Several studies of energy requirements for packaging alternatives were carried out in the early 1970s (e.g., [7–9]). Other applications of interest included gasohol [10] and the proposed solar powered satellite [11]. Net energy analysis was developed as a formalized methodology over a period of years, with significant contributions published in the journal *Energy Policy* in 1974–75 and collected in book form by Thomas [12]. Input–output models were first used for energy analysis by Herendeen [13], Herendeen and Bullard [14], Ayres et al. [15], and Bullard et al. [16]. Virtually all of these studies were concerned with energy resource availability and energy efficiency. None of them considered energy-related waste emissions explicitly.

One of the first attempts to carry out a life cycle analysis taking into account waste emissions generated by direct and indirect production processes (as opposed to a 'net energy consumption') was sponsored by the US National Science Foundation's program of Research on National Needs (RANN) in the early 1970s. The case selected for analysis was a comparison of glass, polyethylene (PE) and polyvinyl chloride (PVC) bottles [17–19]. This effort concentrated mostly on developing a model (the 'materials-process-product model') to carry out what is now called the 'inventory phase' of the analysis, although it also included elements of a policy assessment. Another early effort, also focussed on the resource and environmental impacts of packaging alternatives, was a report to the US Environmental Protection Agency [20].

The first major example of a public controversy focussed on environmental impacts of products that was addressed using LCA seems to have been the unresolved competition between reusable cloth diapers and disposable paper diapers [21–23]. In this case, disposables create 90-times more solid waste (but only 2% of the total of municipal waste), whereas reusable cloth diapers generate 10-times as much water pollution (including detergents) and consume 3-times as much energy [24].

¹ SETAC is the Society for Environmental Toxicology and Chemistry. It is an international scientific society with 3000 members from academic institutions, regulatory bodies, independent research institutes and industry. SETAC-Europe has created a steering committee to "identify, resolve, and communicate issues regarding LCAs (and to) facilitate, coordinate and provide guidance for the development and implementation of LCAs". In cooperation with SETAC-North America five workshops have been held: (1) Inventory (Vermont, August 1990); (2) Impact Assessment I (Leiden, December 1991); (3) Impact Assessment II (Sandestin, Feb. 1992); (4) Data Quality (Wintergreen, Oct. 1992); (5) Code of Practice (Sesimbra, April 1993). The proceedings of each workshop are published in book form and available from SETAC.

Another classic example of a public controversy was the McDonald's case involving a choice between groundwood (papier-maché) vs. polystyrene hamburger shells. This was ultimately decided by McDonald's in favor of the former, but apparently in response to a 'green' campaign that had already prejudged the issue. It is not at all clear that, when manufacturing processes are considered, polystyrene causes more environmental harm than either virgin or recycled paper pulp. In a similar case, it has been estimated recently that, although polystyrene foam cups occupy more space in landfills than paper cups, the latter requires 36-times more electricity and 580-times more wastewater to manufacture [25]. In addition, when paper is buried in a landfill it eventually decays anaerobically, generating methane.

The packaging industry has been the target of a disproportionate number of LCAs. Other examples include the competition between returnable and re-usable glass bottles, recyclable glass bottles, recyclable aluminum cans and various non-recyclable plastic containers (e.g., [26–36]).

In none of the above cases has LCA or eco-profile analysis offered a clear-cut answer. In part this arises from the difficulty of comparing eco-profiles with completely different characteristics. How is the analyst to choose between a theoretically biodegradable product manufactured by a dirty process and a non-biodegradable product whose manufacturing process is relatively clean? The choice could well depend on the mode of disposal, which is very much a policy question itself. Thus, if municipal waste is disposed of in a traditional open landfill, paper will eventually be consumed by decay bacteria, whereas polystyrene will not. However, if solid waste is to be stored indefinitely in modern airtight and waterproof landfills, or if it is incinerated for energy recovery, polystyrene should probably be preferred to paper on the basis of a cleaner manufacturing process. Evidently, in many –perhaps most –cases LCA can only expose the tradeoffs. It can only rarely point unambiguously at the 'best' technological choice. I return to the question of valuation subsequently.

But LCA suffers from another problem that is less obvious, but not less serious. A detailed critique of the above-cited studies (among others) would require a substantial effort. However, all the studies of which I am aware –a *caveat* that excludes unpublished studies done by or for a firm for its own use –suffer from a generic deficiency. There are two aspects to the problem. The first is the persistent use in many studies of non-comparable units of measurement. In particular, LCA manuals published by SETAC actually specify that energy data should be specified in energy units (such as joules), whereas other purchased material inputs and outputs are to be measured in mass terms. To simplify the presentation (incidentally ensuring that no reader will be able to reproduce the chain of argument for himself), the aggregated inputs (fuels and feedstocks) are given in energy units (MJ), while emissions to air and water are presented in mass units.

Unfortunately, in many published LCAs the masses are allocated to a set of categories that were initially used by civil engineers designing sewage treatment facilities or incinerators, viz. 'dust', 'metals', 'suspended solids', 'dissolved solids', 'dissolved organics', 'miscellaneous refuse', 'industrial waste', 'mineral waste' and 'non-toxic chemicals'. But the actual physical composition of these waste streams is rarely given, either for inputs or outputs. Nor is the use of process water specified as such. Thus, it is impossible to distinguish dry waste from wet waste, or to verify whether the data presented satisfy even a simple

mass balance, never mind a detailed balance for such key elements as carbon, sulfur or chlorine.

If the problems of environmental concern were only dust, dissolved solids, etc. (the categories noted above) this mode of presentation might not be seriously misleading. However, it is misleading to mention of the toxic and hazardous pollutants of major concern from a public health standpoint. Furthermore, waste emissions are specified in terms of mixed units such as BOD or COD (which cannot be exactly translated into mass of pollutants) or in terms of mass with indeterminate composition (e.g., particulates, dust, suspended solids, dissolved solids, 'industrial waste', 'miscellaneous refuse', etc.)

In my opinion, practitioners of LCA have consistently failed to insist on the use of common and comparable mass units. Rather, they have accepted (even encouraged) the use of incompatible and non-comparable units. For instance, LCAs typically attempt to separate energy carriers (measured in joules or some other energy unit) from 'feedstocks', which would normally be measured in mass units. This is traditional among government and industry accountants and statisticians. But the distinction is arbitrary and dangerously misleading when applied to chemical processes where the process heat is produced by partial combustion of a feedstock yielding an intermediate (such as carbon monoxide) that participates chemically in the rest of the reaction. Major examples of this include ammonia and methanol synthesis and carbothermic smelting of metals, but there are literally scores of other examples.

It is both unnecessary and extremely confusing to insist on counting feedstocks and fuels in separate categories in such cases. There is no real physical distinction between them. But if energy carriers and combustion wastes are not counted in mass terms, no materials balance is possible. Moreover, by confusing fuels and feedstocks it is possible to claim that the yield of products from feedstocks is arbitrarily high (say 98% or 99%) with the disguised implication that process emissions are nearly zero. It also implies that emissions of unreacted feedstocks or wastes are nearly zero. The further implication, whether intended or not, is that there is no room (or need) for improvement. Moreover, by measuring fuels, feedstocks, and wastes in different units, there is no way to carry out a mass balance to compare outputs with inputs. For this reason, among others, the mass balance principle is rarely applied in practice at the commodity or industrial levels, even though it is a standard tool in process design (e.g., [37]).

The second aspect of the data deficiency problem is the near universal dependence on either somewhat theoretical process data from open sources (such as chemical engineering publications or patent literature) that does not necessarily reflect actual practice, or on unpublished primary data from 'confidential' (and consequently unverifiable) sources. Such data is often internally inconsistent (i.e., unbalanced). Some of these 'data' are physically impossible. In addition, different authors analyzing the same rather standard product commonly differ by orders of magnitude in regard to specifics. These differences are far greater than can be accounted for by any plausible scientific uncertainty. The combination of these issues leads us to consider the 'data problem' in more detail.

2. Inconsistent, unverifiable data

To be absolutely clear, the data problem I want to address is *not* attributable to inherent uncertainties of measurement. To be sure, uncertainty is a fact of life in all matters pertaining

Table 1
Polypropylene: Comparison of three LCAs (kg per 1 metric ton)

	Case 1. FOEFL 132 (Habersatter)	Case 2. PWMI (Boustead)	Case 3. CSG/Tellus Institute	
	average, Switzerland	average, Europe	controlled, US	uncontrolled, US
Dust (TSP)	0.245	2.0	4.88	13.42
PM ₁₀	na	na	2.00	7.52
Carbon monoxide	1.980	0.7	1.248	123.6
Carbon dioxide	na	1100	na	na
Sulfur oxides (SO _x)	3.403	11.0	39.8	79.0
Nitrogen ox. (NO _x)	6.407	10.0	13.9	166.4
Hydrogen chloride	0.000	0.04	na	na
Hydrocarbons	11.936	13.0	na	na
Methane	na	na	0.191	0.191
Aldehydes	0.000	na	0.000	0.170
Vol. org. (VOC)	0.000	na	0.312	167.6
Hydrogen sulfide	na	0.01	na	na
Hydrogen fluoride	0.000	0.001	na	na
Metals	na	0.005	na	na
Lead	na	na	0.0063	0.0063
Ammonia	0.000	na	0.000	0.482
Benzene	na	na	0.0084	0.0084
Benzo(a)pyrene	na	na	< < 0.0001	0.0043
Biphenyl	na	na	0.0123	0.0123
Ethylbenzene	na	na	1.044	1.044
Naphthalene	na	na	0.678	0.678
Styrene	na	na	na	na
Toluene	na	na	0.0244	0.0244
Xylene	na	na	0.0886	0.0886

to the physical world. All physical measurements are uncertain to some degree. In many cases, of course, the degree of uncertainty is itself a known quantity and statistical analysis is applicable. In other cases the uncertainty is, itself, uncertain (i.e., the distribution of errors is not well characterized). A competent analyst recognizes these facts, tries to put bounds on the range of uncertainty, and moves on.

The problem for LCA is much less sophisticated but much more urgent: it is the persistent use in LCAs of 'data' from unreliable sources that cannot be checked. Many LCAs do not even publish the underlying data. To put the problem into perspective, consider Table 1 and Table 2, which compare three well-known LCAs (two European, one American) in terms of their treatment of airborne emissions generated during the production of two commodity plastics, polypropylene and polystyrene. Case 1 was extracted from a study of packaging materials undertaken by scientists at the Swiss Federal Institute of Technology (ETH) in Zurich, for the Swiss Federal Office of Environment, Forests and Landscape (FOEFL) in 1991, to update an earlier (1984) study [38]. Case 2 was taken from a series of four LCAs carried out recently by the European Center for Plastics in the Environment (PWMI), which is a unit of the Association of Plastics Manufacturers in Europe (APME) [39–41]. Case 3 was extracted from a study of packaging materials sponsored by the Council of State Governments (CSG), the Environmental Protection Agency and the New

Table 2
Polystyrene: Comparison of three LCAs (kg per 1 metric ton)

	Case 1. FOEFL 132 (Habersatter)	Case 2. PWMI (Boustead)	Case 3. CSG/Tellus Institute	
	average, Switzerland	average, Europe	controlled, US	uncontrolled, US
Dust (TSP)	0.978	3.1	5.9	7.6
PM ₁₀	na	na	2.56	3.6
Carbon monoxide	2.956	1.4	2.06	86
Carbon dioxide	na	1600	–	–
Sulfur oxides (SO _x)	9.371	34.0	47.2	56.6
Nitrogen ox. (NO _x)	10.068	24.0	17.6	20.6
Hydrogen chloride	0.000	0.04	–	–
Hydrocarbons	26.651	26.0	–	–
Methane	na	–	0.29	0.29
Aldehydes	0.003	–	–	0.116
Vol. org. (VOC)	0.005	–	0.31	96.4
Hydrogen sulfide	na	0.002	–	–
Hydrogen fluoride	0.000	0.001	–	–
Metals	na	0.01	–	–
Lead	na	na	0.008	0.008
Ammonia	0.001	na	–	0.33
Benzene	na	na	3.86	11.44
Benzo(a)pyrene	na	na	< < 0.0001	0.0029
Biphenyl	na	na	0.0084	0.0084
Ethylbenzene	na	na	0.784	0.784
Naphthalene	na	na	0.464	0.464
Styrene	na	na	0.208	0.208
Toluene	na	na	0.0168	0.0169
Xylene	na	na	0.0608	0.0608

Jersey Department of Environmental Protection and Energy, and performed by the Tellus Institute in Boston [42]. In each case, the table presents composite emissions including petroleum refining, power generation and all prior processing steps back to raw materials.

The first point that commends itself to notice is that the two European LCAs (FOEFL and PWMI) both aggregated the wastes into broad categories, like 'hydrocarbons' without specifying composition. Thus, neither European study provides any information about the emissions of toxic or carcinogenic compounds such as benzene, benzo[a] pyrene, ethylbenzene, styrene or toluene, all of which are dangerously toxic or carcinogenic and of major concern to the public. In both cases, it must be inferred that the authors (or the sponsors) did not consider these emissions to be significant. The supporting text makes it clear that both authors (Habersatter/Widmer and Boustead) assumed energy consumption (and associated emissions) to be the dominant environmental concern. Second, they both presented 'averages' without specifying the degree of pollution treatment (or by implication) the potential for further abatement. By contrast, the CSG/Tellus study provides details on the composition of both untreated and treated wastes.

The second point to notice is the surprising disparity between FOEFL and PWMI, with respect to major emissions, including dust (particulates), CO, SO_x and even NO_x. Ratios of FOEFL estimates to PWMI estimates for these four emissions in the case of polypropylene

are 0.123, 3.54, 0.308 and 0.64. In fact, the only near-agreement between the two is for the 'hydrocarbon' category. The comparison in the case of polystyrene is similar, if not quite so bad.

Table 1 and Table 2 raise some vital questions. Is it possible that the differences between the three cases are explainable in terms of differences between 'Swiss', 'European' and US conditions? In other words, is it possible that they are all 'correct' after all? Setting aside the possibility of some difference between Europe and the US as regards fuel mix for electric power generation, the FOEFL study explicitly uses a pan-Europe model, both for energy supply and for materials not produced in Switzerland: "Contrary to the order, the study cannot be limited to Switzerland. Raw materials and energy carriers are imported from all over the world, some packaging materials are not even manufactured in Switzerland" [43]. In fact, polypropylene and polystyrene are both manufactured outside of Switzerland. In effect, FOEFL and PWMI refer to exactly the same geographical region, namely western Europe. Since both studies explicitly refer to the same products made in the same area by the same technologies, in the same time period (approx. 1988–1990) the results should be the same, or at least very similar. In short, since they differ sharply, they cannot both be correct.

Why the differences between case 1 and case 2? The answer must be either (a) that different data sources were used or (b) that there were different underlying assumptions about energy use, despite the fact that both cases apparently referred to the same thing. Since the only point of agreement between the two cases in Table 1 was in regard to 'hydrocarbon' emissions (presumably from process losses), it seems likely that the differences are largely attributed to different assumptions about energy production and fuel mix. The Swiss study explicitly assumed a pan-European average energy supply, whereas the PWMI study seems to have drawn its boundaries somewhat differently. The result is that imputed emissions per unit of plastic are dramatically different. Yet they cannot both be right.

As regards process-related emissions, both FOEFL and PWMI are woefully lacking in detail. In the FOEFL case, process emissions were at least explicitly distinguished from non-process (i.e., energy, transportation, etc.) emissions, but both are presented in terms of the same categories (e.g., 'hydrocarbons'). At least, the identities of the sources were well documented. Data on plastics production –presumably including emissions –were provided by named individuals at three firms, namely BASF and Hoechst (Germany) and Courtaulds (UK). (Reference was also made to two published reports on energy use by the plastics industry, dated 1980 and 1977.) Flow charts for the production processes are shown with, however, no explicit source reference for the emissions assumptions.

As regards PWMI, essentially no checkable source references whatever were given (except to other published reports by the author). The following is typical:

"Information has been obtained from three operators of North Sea oil rigs. In each case the operator supplied information on the production of gas and oil, the quantities of different fuels and materials used as well as data on the *estimated* air, water and solid waste emissions..... When the statistical data and the operators data are combined, the overall typical performance of North Sea production is summarized in Table 6 for gas feedstock and Table 7 for oil feedstock" [44]. or

“The distribution shown in Tables 12 and 13 is based on information supplied by the different operators but some of the returns did not provide complete data on the quantities of feedstock subsequently used as fuels. In general, it appears that there is a 5% real loss of feedstock materials in those processes leading up to the production of monomer, with a further 1% loss at polymerization; any excesses above these levels are used as fuels” [45].

The tables referred to in the above quotes aggregate inputs to a whole chain of processes by a procedure that is only partially described. Whereas FOEFL and CSG/Tellus present extensive and detailed appendices, nothing of the sort is provided by PWMI.

I note here that Boustead’s assumption of only a 1% loss in polymerization (of ethylene and propylene) in the second quotation, above, is almost certainly far too optimistic. Stanford Research Institute’s estimates of loss (the complement of yield) are 2% for HDPE, 2–3% for LDPE and 9% for polypropylene [46]. I do not know whether SRI is right or not, but Boustead’s more optimistic estimate is not supported by any of the data presented. Similarly, his estimate of 5% loss in all processes leading up to the monomer (mainly naphtha cracking) must be equally questionable. (This issue is hardly a minor one, inasmuch as the major process emissions to air or water, prior to any end-of-pipe treatment are essentially identical to these losses.) Boustead assumed, again without reference to any source, that any feedstock losses beyond the 1% and 5% levels, respectively, are simply recaptured and burned as fuel. This assumption may or may not be justified. But the point I am making is that *it is an assumption*. In making this assumption (which seems rather arbitrary) Boustead could well be assuming away emissions of toxic and carcinogenic pollutants by a significant factor ².

Both European studies, FOEFL and PWMI professed to utilize materials balances, but neither actually did so. Both also depended largely on ‘confidential’ sources of data. (The CSG/Tellus study, by contrast, did not attempt to use mass balances, but did explicitly rely only on published data sources, albeit some of them were admittedly out of date.) The word ‘balance’ is featured in the title of the FOEFL study, and the term is elaborated in one section of the report [47]. Balances are exhibited in most of the flow charts (see, however, below). The PWMI study was performed by one of the intellectual leaders of the SETAC effort to standardize LCA. In the SETAC documents there is considerable emphasis on the use of materials balance. Yet the PWMI study makes no attempt to utilize this elementary methodology in its published reports.

The executive director of PWMI, the sponsor, asserted without qualification that detailed materials balances were actually available for each process and had been used in the Boustead study (Matthews, personal communication). Asked why –if available –mass balances were not presented in the report, he replied that the expert committee (of which Dr. Boustead, the consultant, is also the chairman) had ‘not recommended’ it. Matthews asserted that the committee members were ‘the outstanding practitioners’ in the field and denied absolutely that a desire for secrecy by the industrial sponsors of the study was in any way a factor.

² In the case of polyethylene and polypropylene, the most dangerous emission is probably ethylene itself, which is listed by EPA as a ‘toxic’ chemical, but is not extremely hazardous. On the other hand, the same procedure in the case of polystyrene would minimize the apparent emissions of benzene, ethylbenzene and styrene (and toluene), all of which are major public health hazards.

Table 3
Inputs per metric ton of dry paper pulp (Kraft process) by two LCAs

Input material (kg)	Sulfate pulp, unbleached		Sulfate pulp, bleached	
	FOEFL	CSG/Tellus	FOEFL	CSG/Tellus
Wood chips, dry	2000	2200	2200	2330
Lime (CaO)	7	15.5	7	16.4
Sodium sulfate	16.7	65.5	–	69.3
Sodium hydroxide (NaOH)	11.1	–	24	61
Sulfuric acid (H ₂ SO ₄)	–	–	18	–
Chlorine (Cl ₂)	–	–	15	37
Sodium chlorate (NaClO ₃)	–	–	18	N.A.
Oxygen (O ₂)	–	–	16	–
Peroxides	–	–	2.2	–
Sulfur dioxide (SO ₂)	–	–	11	–

Nevertheless, the LCA reader—a legislator, regulator or member of some public interest group—is asked, in effect, to take the PWMI's consultant's unsupported word for the validity of the data presented. The consultant, in turn, apparently accepted the unsupported word of the firms supplying the data, which are also the ultimate sponsors of the LCA.

In two respects, the CSG/Tellus study is far superior to the other two, namely the detailed breakdown of airborne emissions by chemical species (which is equally true of waterborne emissions) and its consistent use of published data. In the introduction, one finds the following: “Third, we made a fundamental decision to *rely solely on public sources of information*. We used government databases, and other information available in the public domain. To be included in our study, data had to be accessible to all researchers...” [48]. Evidently this self-imposed restriction was not a major drawback. Indeed, the CSG/Tellus report contains far more data than either of the others.

Lest the reader conclude that I am offering the CSG/Tellus study as a paragon, let me now turn to another problem, namely the use of ‘idealized’ process data. In the CSG/Tellus study (as also in the FOEFL study) there is a detailed analysis of the paper industry, since paper products are very important packaging materials. The three most important chemical paper pulping processes are the Kraft (sulfate) process, the sulfite process and the semi-chemical process. Tellus considers only the first two (as does FOEFL). The process inputs assumed in the two studies are as shown in Table 3.

Differences here may conceivably be due to differences in practice in Europe vs. the US. However, ‘real’ data about the pulp and paper industry is exceedingly difficult to find. FOEFL has relied largely on industry statements. Tellus, on the other hand, has relied almost exclusively on a process description in a book [49], which was almost certainly somewhat idealized at the time, and is now certainly obsolete, due to rapid changes in the industry. The problem is easily demonstrated: based on 1988 US output of Kraft pulp (43.5 million metric tons, at 10% moisture content) the figures in Table 3 imply that the paper/pulp industry would have consumed 2.82 million metric tons of sodium sulfate and 670 thousand metric tons of lime. In actuality, the US pulp and paper sector—as a whole—consumed only 480 thousand metric tons of sodium sulfate and 1.14 million metric tons of lime!

Without pursuing the details further, it is enough to say that the list of chemicals actually used by the US pulp and paper sector bears little resemblance to the list implied by the Tellus data. In this case the FOEFL report is likely to be much nearer the mark. But I cannot help pointing out that it would not be unduly difficult to check these data as I have done, by comparing total consumption of chemicals by the industry with reported consumption per unit.

A related data problem is that, in some cases, process data used in LCAs actually violate the laws of physics. Yet the data are commonly used such a way that their inconsistency – physical impossibility – is effectively obscured. For instance, chemical process descriptions, as published in standard encyclopedias (e.g., [50,51]), are also almost always unbalanced. In all of the standard sources of process information, waste streams are simply neglected. This is also true of the process data in Stanford Research Institute's Process Economics Program (PEP), which is proprietary but widely used in the chemical industry.

The following simple example illustrates this point. Ethyl chloride (C_2H_5Cl) is a chemical used in the manufacture of tetraethyl lead. One (obsolete) manufacturing process was to react ethylene (C_2H_4) directly with anhydrous hydrochloric acid (HCl) in the presence of an aluminum chloride catalyst. According to the published process description, the reaction requires 488 kg of ethylene and 625 kg of hydrogen chloride to yield 1 metric ton (1000 kg) of ethyl chloride [52]. The process inputs add up to 1113 kg. It seems that 113 kg of mass has disappeared from the output side of the process. This is an obvious violation of the first law of thermodynamics, namely the conservation of mass. Thus, the sum total of mass inputs to the process is typically greater than the sum total of process outputs. The neglected outputs are, of course, wastes.

Understandably, chemists in the past have been relatively uninterested in the detailed composition of process waste streams. Moreover, chemical engineering reference books tend to simplify process descriptions, since authors do not have access to proprietary company data on yields, catalysts and process conditions (temperatures, pressures, reaction times). But past disinterest in process waste streams on the part of the chemists and chemical process designers is no excuse for total neglect of this problem in LCA where the whole point of the exercise is to account for process wastes and environmental pollutants.

Worse, the casual neglect of elementary mass balance considerations permits errors of all kinds – even typographical and transcription errors – to go undetected. Table 4 above is an example of an impossible process taken from the so-called IDEAS data base, created by the International Institute for Applied Systems Analysis (IIASA) for LCA [53]. The IDEAS database remains unpublished because, initially, IIASA was hoping to license the entire system, data included, to LCA practitioners. Unfortunately, anyone who used it might have encountered some surprises.

In this case, by-product ammonia and tar are overstated by large factors; two orders of magnitude in the case of by-product ammonia and at least one order in the case of tar. The authors of the study (in response to a critique by me) made a formal attempt to balance the total material inputs against the total material outputs. However, instead of searching for the error, they forced a 'mass balance' by arbitrarily including 'process air' on the input side and neglecting the corresponding output of nitrogen. There is no such thing as 'process NH_3 ' in a coking plant. The original problem is almost certainly attributable to a transcrip-

Table 4
Materials balance for basic coking process from IIASA's IDEAS database [73]

Utility inputs			
Electricity		0.0426 kWh	
Heat		4.393 GJ	
Quantities below in mass units per 1 mass unit of output (Coke)			
Inputs		Outputs	
Water, process	12.48	Water, process	12.333
Air, process	1.60	Water, waste	0.05
		Steam (output)	0.35
		Carbon dioxide (CO ₂)	0.0175
		Sulfur dioxide (SO ₂)	0.00150
		Carbon monoxide (CO)	0.00120
		NO _x	0.000700
		BOD ₅	0.000640
		VOC	0.000300
Subtotal	14.08		12.75
Coal, coking	1.41	Coke (unit output)	1.00
		Ammonia, process (NH ₃)	0.682
		Tar	0.530
		Offgas, coking	0.250
		Coke breeze	0.163
		Oil, light crude	0.133
		TSP	0.00100
		TSS	0.000170
		Cyanides	0.000056
		Oil & grease	0.000010
		Cadmium (Cd)	0.00000002
Subtotal	1.41		2.76
Total	15.49		15.51

tion error. However, it does not matter how the error was created. The point is that the mass balance was not used to detect and correct the error, but rather to disguise it.

IIASA is not the only respected organization generating LCAs from impossible data. Here is another example, from the FOEFL report, published by the Swiss government [54], reproduced below as Table 5. It is trivial to verify that mass balance conditions are not satisfied. For instance, in the case of PVC the total of 'used materials' input per kg is 1930.82 g per kg of product, while products (including PVC itself) and by-products add up to 2174.47 g not including emissions. The inconsistency is not immediately obvious, since the input list is itself incomplete (atmospheric oxygen is omitted, for example, as are fuels) and the output list (not shown) omits major mass flows like carbon dioxide and water vapor. Nevertheless, it is easy to see that the missing mass on the output side is greater than the missing mass on the input side.

It seems likely that there are omissions on the input side, or else 'by-products with calor. value' have been double-counted. However, it is impossible to cross-check the calculations or reconcile the obvious discrepancy. Unfortunately, the example illustrated is by no means an isolated case.

Table 5
Ecobalances of plastics

	Unit	HD-PE	LD-PE	PET	PP	PS	HI-PS	PVC
Balance per kg plastics								
Used materials								
Petroleum	g	1964.21	1966.42	4014.37	1964.21	3493.89	3406.56	906.35
Hydrogen	g	1.88	1.88	23.52	1.88	6.48	6.20	0.87
Oxygen	g			527.00				
Rock salt	g							1016.43
NaOH	g			0.45				
By-products	g			-1303.85		-321.32	-301.55	-716.28
By-products with calor. value	g	-945.46	-9.50	-2103.20	-946.96	-2189.44	-2116.51	-458.19
Adjuvants, additives	g	9.00	3.78	0.06	1.30	35.05	35.11	7.17
Miscellaneous	g	5.00		20.07				
Energy carriers (excl. transp. + electr. prod.)								
Fuel gas	dm ³	255.35	255.63	189.00	227.00	108.00	114.00	192.56
Residues with calorific value	g	418.49	418.96	652.00	381.43	407.00	406.00	193.11
Steam	kg	-3.29	-3.96	0.32	-1.45	2.11	2.23	0.89
Energy balance								
Energy from material input	MJ	44.36	43.74	35.10	43.66	40.93	41.37	17.24
Process energy	MJ	19.00	16.94	38.74	21.98	29.88	30.44	20.14
Auxiliary plants	MJ	0.17	0.19	0.60	0.35	0.21	0.24	0.67
Precombustion	MJ	-0.96	-1.15	0.15	-0.40	0.64	0.68	0.33
Total production								
Thermal energy	MJ	62.57	59.72	74.59	65.59	71.66	72.73	38.37
Electric energy	kWh	0.53	0.88	1.04	0.57	0.38	0.41	1.34
as per UCPTPE 88	MJ	67.6	68.1	84.5	71.0	75.3	76.6	51.1
Disposal								
Credit WIP	MJ	-20.78	-20.78	-15.07	-21.12	-19.15	-19.20	-8.64
Transportation	MJ	0.04	0.04	0.04	0.04	0.04	0.04	0.04
Total production & disposal	MJ	41.83	38.98	59.56	44.52	52.55	53.57	29.77
as per UCPTPE 88	kWh	0.53	0.88	1.04	0.57	0.38	0.41	1.34
E eq	MJ	46.9	47.3	69.5	50.0	56.2	57.5	42.5

Source: [74].

To emphasize that the use of unbalanced (i.e., impossible) data is not a rare and exceptional problem, consider Fig. 1 taken from the same LCA cited above [55]. In this case a number of processes leading into primary aluminum smelting are aggregated into a much smaller number. The process inputs seem to consist of 27.5 kg of bauxite, 2.4 kg of an output of electrolysis of rock salt (actually sodium hydroxide, NaOH) and 0.5 kg of some output of calcination of limestone (lime, CaO). While the diagram is quite confusing, it appears that 30.4 kg of inputs flow into process K (aluminum fluoride manufacturing), producing 18 kg of product, leaving 12.4 kg of inputs unaccounted for. This, in itself, is an impossibility.

Worse, Fig. 1 aggregates the production of the two different materials, aluminum fluoride and synthetic cryolite (sodium-aluminum-fluoride) under the single label 'aluminum fluoride'. Taking them together, it shows 18 kg of this material being used per metric ton of aluminum. Although the diagram does not show it, the fluorine is lost in the electrolysis because it is released when aluminum is electro-deposited on the anode, and the only reason for adding aluminum fluoride to the electrolytic bath is to replace this loss. The sodium in the synthetic cryolite obviously comes from an input stream of sodium hydroxide, as correctly indicated by Fig. 1. The aluminum in both chemicals is ultimately derived from bauxite, although there is actually an intermediate stage (refined alumina).

However, Fig. 1 completely omits any source of the element fluorine! In the real process fluorine would be derived either from hydrofluoric acid or another precursor such as fluosilicic acid. This omission is not accidental. That is, it is not a simple mistake in drawing the diagram. A detailed account of inputs and outputs to the aluminum fluoride manufacturing process is found in the Appendix of the document (Table A.1.7. 'Production of Aluminium Fluoride'), again lacking any source of fluorine (although emissions of HF are mentioned). The omission is hardly unimportant: fluorine in air emissions is the single most dangerous pollutant in the aluminum reduction process.

It is evident that the inconsistent data came from an unpublished, 'confidential' or 'proprietary' industry source. The omission of fluorine was probably sheer carelessness on the part of whoever provided the data. It would have been uncovered by a systematic use of materials balance for fluorine. But the practice of disguising the source of such data obscures the fact that process descriptions available from published sources are nearly always *unbalanced*, i.e., inconsistent and thus physically impossible. Fluorine compounds cannot be produced by a process without a fluorine input. Such a diagram, or the accompanying table—presented without backup calculations or references—cannot be trusted. Nor can any LCA based on it be trusted. Nor, to be blunt, can one trust any LCA produced by a similar procedure.

It cannot be argued that the above examples are rare exceptions, or that the authors did the best possible job in the circumstances. The damage is self-inflicted. It arises from several causes: (1) an inappropriate preoccupation with energy, leading to (2) failure to insist on meaningful and comparable units of measurement, plus (3) a blind unreasonable trust in unverifiable data from 'confidential' sources, without (4) any serious attempt to use mass balances as a means of verification (or, at least, as a means of uncovering errors). Moreover, it is perfectly possible to do better. If data are missing, there are often ways of filling in the missing data, at least approximately, *without assuming physical impossibilities*. I discuss this topic next.

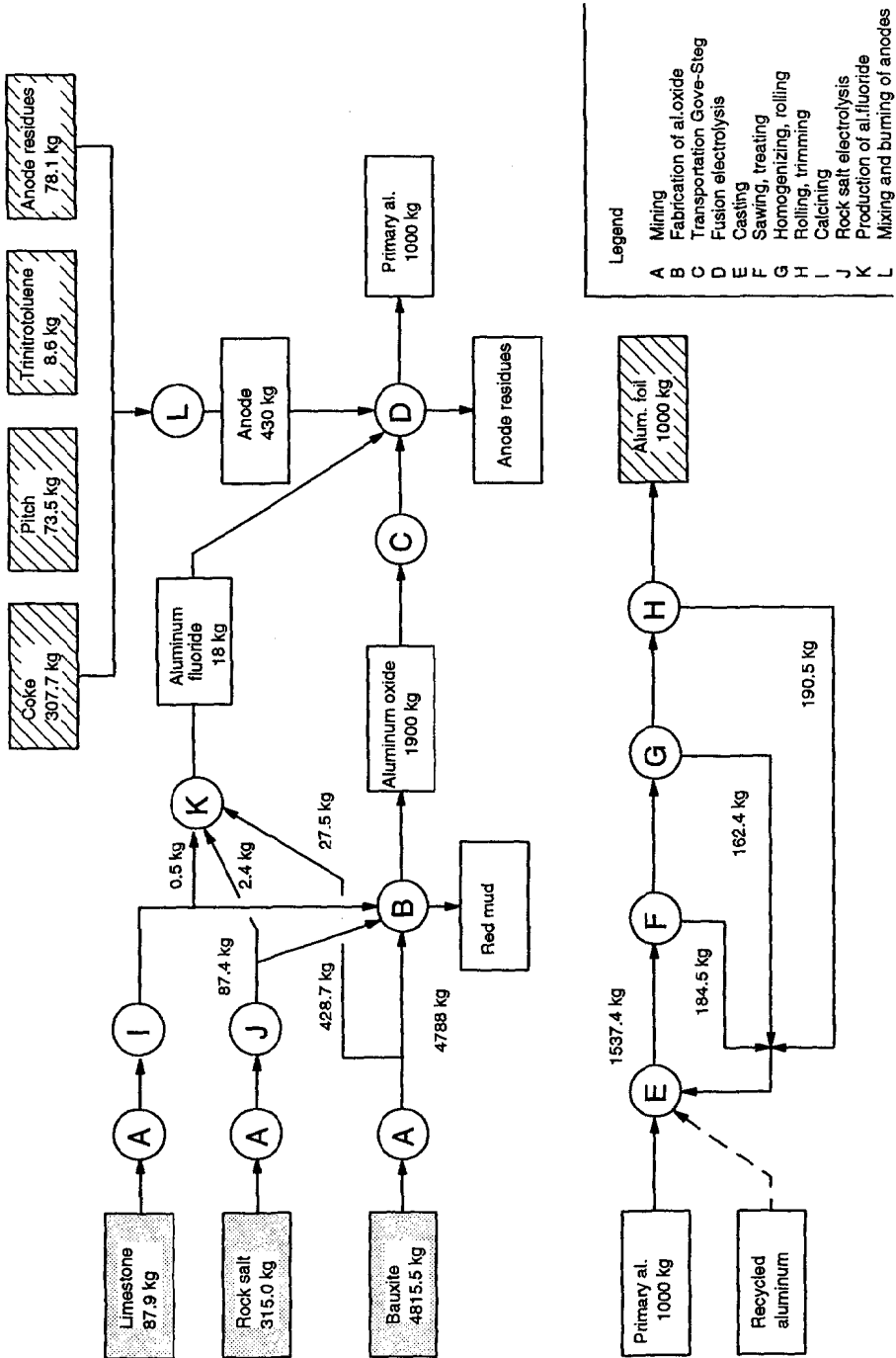

Fig. 1. Material flow chart of aluminum production (production of aluminum after the Bayer-process) [74].

3. Materials/energy balance principle

The laws of physics tell us that mass flows into and out of each process, in steady state, *must* balance. This must be true for both large units and small ones, for each nation, for each region, for each industry and each factory. It must also be true for each unit process, and the balance must apply to each chemical element.

The first law of thermodynamics –conservation of mass-energy –is applicable to every process and every process network. It is, therefore, applicable to every firm and every industry that is in a steady state. This means, in words, that, for every process or process-chain, the mass of inputs (including any unpriced materials from the environment) must exactly equal the mass of outputs, including wastes. For continuous processes, this balance condition must hold for any arbitrary time period³. The materials balance condition is much more powerful than it appears at first glance, since chemical elements do not transmute under normal terrestrial conditions. Taking this into account, the balance condition holds independently for each chemical element. Moreover, in many processes, non-reactive chemical components, such as process water and atmospheric nitrogen, can also be independently balanced. Thus, half a dozen, or more, independent materials balance constraints may have to be satisfied for each steady-state process.

A point of some importance here is that, even if the balances are partly based on theory and not always on direct measurement, the additional conditions imposed by the balancing requirement leave far less room for uncertainty than an unbalanced process would do. In short, systematic use of materials balance conditions can increase the accuracy of empirical data by reducing error-bounds. Alternatively, the materials balance conditions can be used to ‘fill in’ missing data.

Recall the process for manufacturing ethyl chloride described briefly in the last section. According to the published process description, the reaction requires 488 kg of ethylene and 625 kg of hydrogen chloride to yield 1 metric ton (1000 kg) of ethyl chloride [56]. The process inputs add up to 1113 kg. It seems that 113 kg of mass has disappeared from the output side of the process. More precisely, there 113 kg of waste products need to be accounted for. What might these waste products be?

But we can narrow things down by comparing inputs and outputs one element at a time. Inputs of carbon, hydrogen and chlorine, in that order, were 417 kg, 87 kg and 607 kg. Subtracting outputs accounted for in the ethyl chloride product, we have unaccounted for outputs of 45 kg C, 58 kg Cl and 9 kg H. Presumably, the waste (or by-product) stream consists of a number of other compounds of these three elements. In actual fact, according to the same source, the major component of this waste stream should be ethylene dichloride ($C_2H_4Cl_2$). However, if all the excess chlorine ended up in ethylene dichloride the mass of ethylene dichloride would be 81 kg, leaving a bit over 24 kg of C and a bit under 6 kg of H. This comes close –but not quite close enough –to the specification for ethylene. In other words, to make everything come out even, i.e., to get all the reactive elements recombined, a more complex solution is necessary.

³ The case of batch processes or continuous processes with time variability, requires more careful consideration. In general, however, the accounting rule holds: stock changes equal inputs minus outputs. When stock changes are zero, or can be neglected, inputs equal outputs.

One can test various other hypotheses, one by one. Suppose all the leftover chlorine (58 kg) is used up in making ethylene dichloride. Based on the chemical formula given above, it is easy to verify that this would use up a little less than 12 kg of C and 1 kg of H, leaving just over 33 kg of C and 8 kg of H. This combination of masses would work if all the carbon remained in the form of unreacted ethylene (38.5 kg) leaving 2.5 kg of hydrogen gas. Or, suppose all the chlorine were left in the form of unreacted hydrogen chloride? In this case 58 kg of chlorine would use up about 1.7 kg of H, leaving 45 kg of C and 7.3 kg of H. But, even if the carbon and hydrogen combined as methane (CH_4) the available hydrogen could only combine with 22 kg of carbon, leaving 23 kg uncombined (as carbon black?).

Neither of the above hypotheses seems likely, but that is not the point. Notice that all of these possible outcomes can be tested using materials balance information and simple chemical combinations alone, without even knowing the reaction conditions. No deep knowledge of chemistry –the probabilities and rates of reaction –was involved.

Of course, there are many theoretically possible combinations of chemicals in the waste stream that would satisfy the materials balance conditions. But the number of possibilities is much smaller than the number of impossibilities. The latter, at least, can be eliminated from further consideration. In fact, one can do much better by introducing additional data and constraints. The materials balance condition is not the only one that is applicable. The energy conservation condition is another. The energy conservation condition states that the so-called ‘free energy’ (or ‘available work’) used in any endothermic process steps must either be supplied from exothermic processes or by external heat or electricity inputs. Indeed the second law of thermodynamics also implies a constraint that can be expressed as an ‘entropy conservation’ condition: it states that the entropy of process outputs minus the entropy of process inputs must equal the entropy generated by the process itself.

These additional constraints are quite complex to apply in practice. Nevertheless, knowing the thermodynamic properties of the various reactants in a process it is possible to predict their probabilities and rates of reaction as a function of various external conditions (temperature, pressure, electric field). Using this kind of information, far more detailed predictions of complex chemical reaction paths are possible today. In fact, much of this knowledge has been programmed into software packages available even for desk-top computers (e.g., Aspen Plus[®]). In short, it is now feasible to estimate the *molecular* composition of waste streams from the composition of process inputs and approximate knowledge of reaction conditions, notably temperatures, pressures and catalysts.

The logic of materials balance also applies at higher levels of aggregation. There are numerous situations where enough data is available from conventional administrative or accounting sources to permit the missing items to be calculated with high precision. For example, Fig. 2 shows a schematic materials balance for a chemical product. There are 16 distinct mass flows, labelled A through Q. Mass flows A through F represent quantities for which economic statistics are normally available. These are, respectively, domestic (or local) production, by-products of other domestic production processes, net transfers from stock, net imports, dissipative uses and conversion uses. The last two add up to total domestic consumption; however the allocation between them requires some market data that may not be published. The ten streams G through Q, represent other pathways for the chemical, as shown on the schematic. There are five steady-state materials balance conditions that can be used to reduce the number of unknowns. These are as follows:

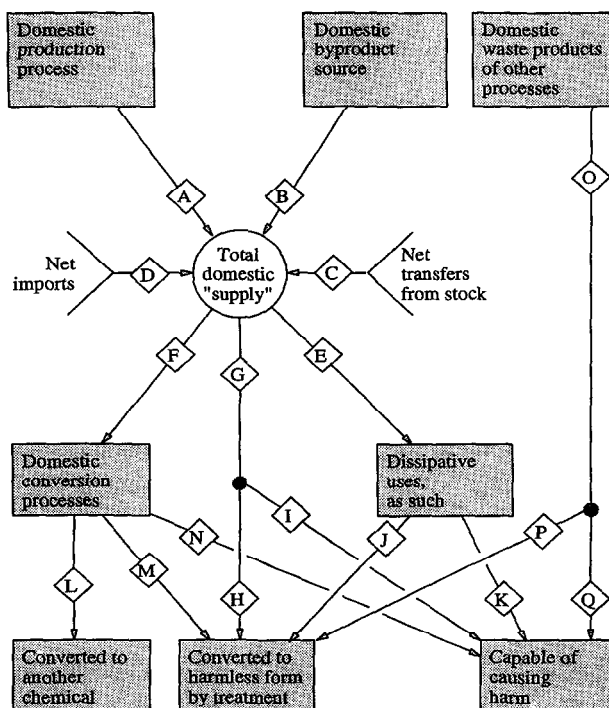

Fig. 2. Materials balance for a chemical product (source: author).

1. $G = A + B + C + D - E - F$ (steady-state supply)
2. $F = L + M$
3. $G = H + I$
4. $E = J + K$
5. $O = P + Q$

This set of equations leaves just five unknowns to be determined by means of process data, especially including treatment processes. As noted, flux G , namely aggregate wastes from the domestic (or local) production process, can be computed most accurately by using accounting data. This is available (in principle) to a plant manager who wants to know, although is not likely to be available to outsiders. However, G can also be estimated from process simulation models –like Aspen Plus® –that are generally available to chemical engineers, as mentioned above. Thus, there are external means of verification.

Next, flux H represents wastes from the domestic production process that are treated on site by impoundment or conversion to a harmless form. This can be determined from the throughput of the treatment process (which must be known to the plant manager, and should also be available to the regulatory agency). An outsider with some knowledge of the process technology would also be able to make use of simulation models for verification purposes. Untreated emissions (flux I) would thus be the difference between G and H . (Direct measurement is a much less reliable means of determination in many cases because of the inherent difficulties involved in detecting small quantities of substances in inhomogeneous, non-isotropic streams of mixed wastes.)

Similarly, the amount of the chemical actually converted into other downstream products, L, can be estimated quite accurately by the on-site process engineer –or by computerized process models available to outsiders –from knowledge of the downstream conversion process yield. The unconverted fraction of inputs must then be treated (flux M) or discharged (flux N). Again, M can be estimated most accurately from the throughput of the treatment or disposal process in use in connection with the conversion process (if any), leaving N as the difference. The same logic applies to dissipative uses. In some cases, at least, it is possible to treat an effluent stream from a dissipative uses, such as solvents, used motor oil or detergents. The stream J accounts for such cases, while K is the untreated remainder. Finally, the same logic applies to the indirect flux O, of which some (P) may be treated, leaving an untreated remainder Q.

Again, direct measurement of emissions is potentially helpful as a means of verifying treatment efficiency process data, but that it cannot be relied upon as the exclusive means of determining aggregate waste flows, especially from dispersed consumption streams. The foregoing scheme can be applied to the estimation of aggregate waste streams at various levels, from the process or product, to the plant, the industry, or the nation.

4. Evaluation: déjà vu?

As noted previously, most of the discussion of LCA methodology currently concerns evaluation methodology rather than data. To give credit where it is due, it is generally recognized that different environmental impacts (‘chalk and cheese’) cannot be legitimately compared. As the PWMI concedes, “unless the comparison is ‘like with like’ the judgment cannot be valid” [57]. Yet, having said this, many studies proceed to reduce all dimensions of the problem to but a single measure. Most commonly, this measure is energy use or ‘energy efficiency’. For instance, virtually all of the studies commissioned or cited by PWMI compare plastic products with others exclusively in terms of energy efficiency. One of the most cited studies is that by Hocking [58], comparing polystyrene with paper cups.

The current generation of LCA practitioners appears to have forgotten some important history. During the mid-1970s, when there was a considerable amount of public concern about energy availability and potential scarcity, many of the same people strongly advocated ‘net energy analysis’ (NEA) as a kind of quick and dirty alternative to economic benefit cost analysis (BCA). The proposals ranged from the relatively modest notion that NEA would be a useful *supplement* to BCA to the much more extreme idea that NEA would be a superior alternative to BCA. It should be sufficient to point out that there is no reasonable objection to the former. However, the latter notion amounts to espousing an ‘energy theory of value’.

The idea that energy would be a better measure of value than money is not new. It has been proposed many times in the past by non-economists of various stripes. Frederick Soddy, the 1921 Nobel laureate in chemistry, wrote several books on the subject and actually started a political party in the 1930s, based on the energy theory of value. Howard Odum, an ecologist, is the best known of the more recent proponents of the idea [59]. The most sophisticated argument in favor of net energy analysis as a substitute for economic valuation (at the macro-level only) makes one major point: NEA accurately measures the use and

depletion of resources that are used in the economy to do useful work, whereas monetary figures are distorted by other factors [60–62].

However, the above argument for energy analysis –whatever its merits –does not justify the use of net energy as a proxy for environmental damage. Internal inconsistencies in the energy theory of value have been pointed out by economists, since Soddy’s time. While markets are often imperfect, it has been proven long ago that, in cases where markets do work well, they allocate resources in a Pareto-optimal manner. To the extent that net energy analysis would imply a different allocation, it would lead to suboptimal results (e.g., [63]). The literature on this issue is extensive, and need not be reviewed here in detail.

The notion of substituting some single measure of environmental impact (other than monetary value) nevertheless continues to be extremely seductive to ecologists, physicists, geographers and various other non-economists. It must be conceded that most of the LCA handbooks and codes of practice try not to overstate the role of energy. Nobody argues explicitly that energy consumption is a legitimate measure of environmental impact. But the published LCAs I have seen, over and over, focus on energy and pay little attention to other factors.

Apart from ‘net energy’, other candidates have been put forward with varying degrees of enthusiasm. One of the most popular, among the recent entries is ‘materials intensity per unit of service’, or MIPS [64]. For a survey of the literature on measures, see [65]. Each has advantages and disadvantages. One of the most pertinent comments that can be made about such schemes is that they are numerous and generally inconsistent with each other [66]. Again, any of these alternatives can be thought of as either a supplement or as a substitute for monetary valuation. Again, there can be no serious objection to the former. In fact, in this spirit, all of the proposed measures can be used together. (But, of course, none of them would then be unique.)

One can, of course, avoid the problem by insisting on multi-dimensionality from the start. Probably the most sophisticated effort along these lines is the *Environmental Life Cycle Assessment of Products* [67]. This valuable document classifies environmental effects into a number of (arguably) independent dimensions, namely:

- Resource depletion
- Human toxicity
- Ecotoxicity
- Acidification
- Nutrification

It develops physical measures and derives quantitative ratings (not just rankings) for a considerable number of resources, pollutants and nutrients. It would then be left to the user of the LCA to provide his own indices of the relative importance of each dimension for a given case. In many ways this approach is the most satisfactory of all, since it seems to avoid the ‘procrustean bed’ of a single measure. It also maximizes the scientific validity of the dimensional measures. But, on the other hand, the idea is to derive a single measure, at the end of the day, albeit only for a specific case. And, the more elaborate multidimensional scheme has the disadvantage (to laymen and political leaders) that the implementation is still rather complex.

In sum, I believe that none of the suggested measures –single or multidimensional –is a satisfactory substitute for monetary valuation, at least in the realm where economic analysis

is applicable. That is the domain where there are (or can be) efficient markets for the exchange of mutually substitutable goods and services, or even of rights and/or privileges of access to services. There are some economists who appear to believe that this realm of actual or potential monetary valuation encompasses virtually everything. Others are willing to concede that there are limits to monetization, viz. where environmental services –or access to them –cannot be contained, quantified or exchanged and environmental disservices cannot be compensated by equivalent economic services. (I am one of the minority that belongs to the second camp.)

It is worthwhile to push the monetization notion to its limits, if only to get a better idea what the limits are. The most popular approach, at present, is known as ‘contingency valuation’ or CV. To simplify a very complex topic in economics, the general idea is to survey consumers (i.e., members of the general public) with respect to apparent willingness to pay for certain environmental attributes, or willingness to accept payment for the lack of them. The basic methodology is the sample survey. Such surveys are inherently expensive and subject to bias. (People tend to tell interviewers what they want to hear, for example), but survey methodologies have become quite sophisticated in recent years, and there are various schemes for adjusting for bias. Nevertheless, the CV approach is not totally accepted on theoretical grounds. Its high cost is also a drawback.

Analysts have been working on the monetary evaluation problem along other lines, as well. This is not the place for a comprehensive survey. However, I think one other approach is worthy of mention, since it takes advantage of the scientifically justifiable quantitative comparisons (e.g., similar to those derived in the *Environmental Life Cycle Analysis of Products* [68]) but derives ‘shadow prices’ for the whole list of pollutants by using a willingness-to-pay measure for only one. Once the quantitative ratings are available, e.g., for human toxicity, one can arguably obtain a willingness-to-pay surrogate by analyzing actual outlays by the public sector to control, or compensate for some toxic substance of major public concern. This scheme has been carried out by the Tellus Institute in its LCA for packaging materials, using lead as the ‘numeraire’.

The method pioneered by Tellus has the advantage of being transparent and reasonably inexpensive. It can be criticized, of course, on the grounds that the public sector is known to be extremely inconsistent in putting a ‘price’ on different risks. Indeed, there is a wide variation of implicit values for reducing exposure to lead, depending on circumstances. (Lead was chosen as a numeraire precisely because several different values could be derived for it.) However, notwithstanding the problems of any one example, it seems to me that this approach for risk valuation is the most promising one, of which I am aware thus far.

It must be said, however, that even in the realm where markets are inherently non-functional, economists would not welcome a ‘scoring model’ or any non-monetary theory of value (e.g., [69]). What they would generally accept, however, is a multi-objective decision-theoretic approach, following in the footsteps of Keeney and Raiffa [70], as developed further by others (e.g., [71]). The modern version is generally known as ‘risk-benefit analysis’ in contrast to ‘cost benefit analysis’. This framework has been adapted to the LCA case recently by Field and Ehrenfeld [72].

5. Summary of conclusions

In summary, the methods and models underlying both many published LCAs and many scenario-building efforts are inadequate to their stated purposes. The problems of LCAs are

(1) failure to publish underlying process data attributable to credible sources, (2) failure to impose materials balance conditions on inventory data (often because of unnecessary and confusing attempts to distinguish energy carriers from feedstocks) and (3) unjustified attempts to substitute implicit energy (or other) inappropriate theories of value for market-based valuation.

To cure (or, at least, abate) the data-related problems it is suggested that LCA 'codes of practice' should insist on the use of common mass units and mass balances for all inputs and outputs displayed in the inventory phase of the analysis. Material inputs and waste emissions should be characterized explicitly in terms of elemental composition, at least, and chemical composition wherever feasible.

Process data should be published in material-balanced form, even in cases where firms claim proprietary secrecy. In fact, standardized process design models exist and are used by most of the world's large chemical firms. A standard set of conditions could be prescribed, for instance by the ISO, for presentation of printouts from these models. (The major element of secrecy is the process yield and details of the reactor operating conditions and catalyst. 'Possible' versions of the process, satisfying all necessary physical constraints, could be presented without any breach of confidence. In fact, this approach has been used successfully for many years by SRI in its Chemical Economics Program.)

More data on metal and chemical production and consumption should be published. The old Census rule that data is suppressed when it might reveal proprietary information (i.e., when three or fewer firms are producing the material) is obsolete. First of all, competition is now worldwide, so that US based firms are in a world market. Second, there is no good reason for governments to protect proprietary information on behalf of oligopolies. In any event, such interests can be protected in other ways, by averaging⁴ over all establishments using the process, extending (if necessary) beyond national boundaries. This should be done at the national level when more than three firms use the same process. However, the averaging could also be extended to the EEC region as a whole in cases where *any* of the member countries have three or fewer competing firms using a given process.

Only with the help of a formal tool like LCA is it possible to make rational judgments on the relative environmental load of competing end-use products or competing processes for producing a given product. The case for (or against) recycling in specific cases also depends on such analysis. This is not to suggest, however, that the desired tool actually exists, except in very primitive form.

There is currently an effort to standardize the methodology by organizations, such as the Society for Environmental Toxicology and Chemistry (SETAC) and the International Standards Organization (ISO). These efforts may be premature. Regrettably, the formalized LCA methodology that has been widely promulgated by such groups is still deeply flawed. It pays lip service to materials balance, but by permitting (even encouraging) mixed and inconsistent units, it reflects the hidden (and false) assumption that environmental impacts are largely attributable to energy consumption.

Because of this serious and unacknowledged bias the protocols for data presentation adopted by virtually all current practitioners (mostly former analysts by background) are inherently incapable of verification by the only means available: a mass-balance accounting

⁴ The average should, of course, be weighted by the level of output of each producer.

system. In consequence, the practitioners depend largely –if not entirely –on the validity of process and emissions data obtained from ‘confidential’ industry sources. Such sources cannot be relied upon blindly. In far too many cases, detailed examination reveals glaring internal inconsistencies. No methodology that allows (and encourages) the use of unverifiable –and often erroneous – data can ever be accepted as an objective basis for comparing products or policies.

The difficulties associated with evaluation are much more widely discussed and acknowledged. The problems are deep, but they are not being ignored. There is a healthy debate, and I suspect that significant progress will occur in the coming years. On the other hand, the danger I see is that LCA will be discredited because of its careless use of inconsistent and sometimes impossible data. I, for one, do not want that to happen.

Acknowledgements

This work was supported in part by the Centre for the Management of Environmental Resources (CMER) at INSEAD and in part by the Science and Technology Directorate D, Environmental Research Social and Economic Aspects, of the European Commission. In addition to the editors of this Journal, I wish to thank several individuals who were kind enough to provide helpful comments and suggestions on a pre-publication version of this paper. These include Dr. Dieter Altenpohl (St Gallen); Mr. Nick de Oude (SETAC, Europe); Mr. Claude Fussler (Dow Europe); Mr. Paul Gilgen (Alusuisse), Dr. Urban Gruntz (Sandoz); Dr. Reinout Heijungs and Dr. Helias Udo de Haes (Leiden); Dr. Joram Krozer (TME, den Haag); Mr. Thierry Mueth (Accor); Mr. Jacques Pictet (EPFI, Lausanne); Mr. Denis Postlethwaite (SETAC, Europe); Dr. Paul Raskin (Tellus Institute, Boston); Dr. David Russell (Dow Europe); Mr. Serge Sidoroff (INTAKTA, France); Dr. Walter Stahel (Product Life Institute, Geneva). None of these people are responsible for any remaining errors or misunderstanding on my part.

References

- [1] Procter & Gamble European Technical Center (org), 1990. Life-Cycle Analysis for Packaging Environmental Assessment, Proceedings of the Specialized Workshop held in Leuven, Belgium, Procter & Gamble European Technical Center, Strombeck-Bever, Belgium, 24–25 September 1990.
- [2] Society of Environmental Toxicology and Chemistry and SETAC Foundation for Environmental Education Inc., 1991. A Technical Framework for Life-Cycle Assessment, Workshop Report, SETAC, Washington DC. (Workshop held in Smugglers Notch, VT, 18–23 August 1990).
- [3] Society of Environmental Toxicology and Chemistry and SETAC Foundation for Environmental Education Inc., 1993.
- [4] Heijungs, R. (Ed.), 1992. Environmental Life Cycle Assessment of Products: Vol. I; Guide, Centrum voor Milieukunde, Leiden, Netherlands (translated from the Dutch).
- [5] Lubkert, Barbara, Y. Virtanen, M. Muhlberger, I. Ingham, B. Vallance and S. Alber, op.cit.
- [6] Smith, H., 1969. The Cumulative Energy Requirements of Some Final Products of the Chemical Industry, Transactions of the World Energy Conference 18 (Section E).
- [7] Hannon, B., 1972. System Energy and Recycling: A Study of the Beverage Industry, Center for Advanced Computation. University of Illinois, Urbana, IL.

- [8] Boustead, I., 1972. *The Milk Bottle*, Open University Press, Milton Keynes, UK.
- [9] Sundstrom, G., 1973. Investigation of the Energy Requirements from Raw Materials to Garbage Treatment for 4 Swedish Beer Packaging Alternatives, Report for Rigello Pak AB, Sweden.
- [10] Chambers, R.S., Herendeen, R.A., Joyce, J.J. and Penner, P.S., 1979. Gasohol: does it or doesn't it provide positive net energy? *Science*, 206: 789–795.
- [11] Herendeen, R.A., Kary, T. and Rebitzer, J., 1979. Energy analysis of the solar power satellite. *Science*, 205: 451–454.
- [12] Thomas, J.A.G., 1977. *Energy Analysis*, Westview Press, Boulder, CO.
- [13] Herendeen, R.A., 1974. Energy Costs of Goods and Services: 1963 and 1967, CAC Document (69), Center for Advanced Computation, University of Illinois, Urbana, IL.
- [14] Herendeen, R.A. and Bullard, C., 1974. Energy Cost of Goods and Services, 1963 and 1967, Document (140), Center for Advanced Computation, University of Illinois at Urbana-Champaign, IL, November 1974.
- [15] Ayres, R.U., 1975. Thomas Betlach and Christopher Decker, The Potential for Energy Conservation with Particular Application to Personal Transportation and Space Heating, Research Report (IRT-404-R), International Research and Technology Corporation, Washington DC, October 1975 (prepared for Energy, Mines and Resources, Canada).
- [16] Bullard, C.W., Penner, P.S. and Pilati, D.A., 1978. Net energy analysis: Handbook for combining process and input–output analysis. *Resources and Energy*, 1: 267–313.
- [17] Ayres, R.U., 1974. James Cummings-Saxton and Martin O. Stern, Materials-Process-Product Model –A Feasibility Demonstration Based on the Bottle Manufacturing Industry, Technical Report (IRT-305-FR), International Research and Technology Corporation, Washington DC, July 1974 (prepared for the National Science Foundation).
- [18] Ayres, R.U. and Cummings-Saxton, J., 1975. The materials-process-product model: Theory and applications. In: Vogeley (Ed.), *Mineral Materials Modeling –A State-of-the-Art Review*: 178–244, Johns Hopkins University Press, Baltimore, MD (Resources for the Future, Inc., Washington, DC).
- [19] Ayres, R.U., 1978. Process Classification for the Industrial Material Sector, Technical Report, United Nations Statistical Office, New York, 15 May 1978.
- [20] Hunt, R.G. and Franklin, W.E., 1974. Resources and Environmental Profile Analysis of 9 Beverage Container Alternatives, Contract (68-01-1848), United States Environmental Protection Agency, Washington DC.
- [21] Barber, E., Fagans, K., Iannazzi, F., Shamel, R., Halloack, K. and Frost, H., 1977. Comparative Analysis of Selected Characteristics of Disposable and Reusable Towels, (PB-275 222/8), Arthur D. Little, Inc., Cambridge, MA.
- [22] Barber, E., Fagans, K., Iannazzi, F., Shamel, R., Halloack, K. and Frost, H., 1977. Comparative Analysis of Selected Characteristics of Disposable and Reusable Napkins, (PB-275 222/8), Arthur D. Little, Inc., Cambridge, MA.
- [23] Franklin Associates. 1990. Energy and Environmental Profile Analysis of Children's Disposable and Cloth Diapers, Franklin Associates, Prairie Village, KS.
- [24] New York Times, 26 February 1991.
- [25] Hocking, 1991. Relative merits of polystyrene foam and paper in hot drinks cups: Implications for. *Environ. Manage.* 15(6): November 1991.
- [26] Fink, P., 1979. Analyse der Verpackung von Joghurt wirtschaftliche, technische and oekologische Bewertung, EMPA and Forschungsinstitut fur Adsatz and Handel der HSG, St. Gallen, Switzerland.
- [27] Franklin Associates Ltd., 1985. Comparative Energy and Environmental Impacts of 21 PET and 11 Refillable Glass Bottles Used for Soft Drink Delivery in Germany, Franklin Associates Ltd., Prairie Village, KS.
- [28] Lundholm, M.P. and Sundstrom, G., 1985. Resource and Environmental Impact of Tetra Brik Carton and Refillable and Non-Refillable Glass Bottles, Tetra Brik Aseptic Environmental Profile, AB Tetra Pak, Malmo, Sweden.
- [29] Lundholm, M.P. and Sundstrom, G., 1985. Tetra Brik Aseptic Environmental Profile, Sundstrom AB, Malmo, Sweden.
- [30] Boustead, I., 1989. Environmental Impact of the Major Beverage Packaging Systems –U.K. Data 1986 in Response to the E.E.C. Directive 85/339 1–4, Industry Council for Packaging and the Environment (INCPEN), London.
- [31] Sellers, V.R. and Jere, D., 1989. Comparative Energy and Environmental Impacts for Soft Drink Delivery Systems, Franklin Associates Ltd., Prairie Village, KS.

- [32] Procter & Gamble European Technical Center (org), op.cit.
- [33] Mekel, O.C.L. and Huppes, G., 1990. Environmental Effects of Different Package Systems for Fresh Milk, (ISBN 90-5191-046-0), Centrum voor Milieukunde Rijksuniversiteit Leiden (CML), Leiden, Netherlands.
- [34] Habersatter, K. and Widmer, F., 1991. Ecobalance of Packaging Materials State of 1990, Environmental Series (132), Swiss Federal Office of Environment, Forest and Landscape, Zurich, February 1991.
- [35] Lubkert, B., Virtanen, Y., Muhlberger, M., Ingham, I., Vallance, B. and Alber, S., op. cit.
- [36] Tellus Institute, 1992. CSG/Tellus Packaging Study: Inventory of Material and Energy Use and Air and Water Emissions from the Production of Packaging Materials, Technical Report (89-024/2), Tellus Institute, Boston MA, May 1992 (prepared for the Council of State Governments and the United States Environmental Protection Agency).
- [37] Rudd, D.F., Powers, G.J. and Sirola, J.J., 1973. Process Synthesis (ISBN 0-13-723353-1), Prentice-Hall, Inc., Englewood Cliffs, NJ.
- [38] Habersatter, K. and F. Widmer, op.cit.
- [39] Boustead, I., 1983. Eco-profiles of the European Plastics Industry: Olefin Feedstock Sources, Report (2), PWMI (European Centre for Plastics in the Environment), Brussels, May 1993.
- [40] Boustead, I., 1993. Eco-profiles of the European Plastics Industry: Polyethylene and Polypropylene, Report (3), PWMI (European Centre for Plastics in the Environment), Brussels, May 1993.
- [41] Boustead, I., 1993. Eco-profiles of the European Plastics Industry: Polystyrene, Report (4), PWMI (European Centre for Plastics in the Environment), Brussels, May 1993.
- [42] Tellus Institute, op.cit.
- [43] Habersatter, K. and F. Widmer, op.cit., p.17
- [44] Boustead, I., 1993. Eco-profiles of the European Plastics Industry: Olefin Feedstock Sources, Report (2), PWMI (European Centre for Plastics in the Environment), Brussels, May 1993. op.cit., p. 5; italics added
- [45] Boustead, I., 1993. Eco-profiles of the European Plastics Industry: Polyethylene and Polypropylene, Report (3), PWMI (European Centre for Plastics in the Environment), Brussels, May 1993. op.cit., p. 9; italics added
- [46] Stanford Research Institute, 1984. Chemical Conversion Factors and Yields, Commercial and Theoretical, Stanford Research Institute, Menlo Park, CA, 3rd edn.
- [47] Habersatter, K. and F. Widmer, op.cit., section 2.3
- [48] Tellus Institute, op.cit., p. 3
- [49] Sittig, M., 1977. Pulp and Paper Manufacture, Energy Conservation and Pollution Prevention, Noyes Data Corporation, Park Ridge, NJ.
- [50] Lowenheim, F.A. and Moran, M.K., 1975. Faith, Keyes, and Clark's 'Industrial Chemicals', Wiley-Interscience, New York, 4th edn., p. 371 et seq.
- [51] Grayson, M. and Eckroth, D. (Eds.), 1985. Kirk-Othmer Concise Encyclopedia of Chemical Technology, John Wiley & Sons, New York, A Wiley-Interscience Publication.
- [52] Lowenheim, Frederick A. and Marguerite K. Moran, op.cit.
- [53] Lubkert, B., Virtanen, Y., Muhlberger, M., Ingham, I., Vallance, B. and Alber, S., 1991. Life Cycle Analysis: International Database for Ecoprofile Analysis (IDEA), Working paper (WP-91-30), International Institute for Applied Systems Analysis, Laxenburg, Austria.
- [54] Habersatter, K. and F. Widmer, op.cit., 4.3.3.
- [55] *ibid.*, 4.1.1.
- [56] Lowenheim, Frederick A. and Marguerite K. Moran, op.cit., p.371 et seq.
- [57] PWMI. Weighing Up the Environmental Balance, PWMI (European Centre for Plastics in the Environment), Brussels, undated.
- [58] Hocking, op.cit.
- [59] Odum, H.T., 1971. Environment, Power and Society, Wiley, New York.
- [60] Gilliland, M., 1975. Energy analysis and public policy. *Science*, 189: 1051–1056.
- [61] Cleveland, C.J., Constanza, R., Hall, C.A.S. and Kaufmann, R., 1984. Energy and the US economy: A biophysical perspective. *Science*, 255: 890–897.
- [62] Hall, C.A.S., Cleveland, C.J. and Kaufmann, R., 1992. Energy and Resource Quality: The Ecology of the Economic Process, University Press of Colorado, Niwot, CO.
- [63] Huettner, D.A., 1976. Net energy analysis: An economic assessment. *Science*, 9: 101–104.

- [64] Schmidt-Bleek, F.B., 1994. *Wieviel Umwelt braucht der Mensch?; MIPS, das Mass fuer oekologisches Wirtschaften*, Birkhauser Verlag, Berlin.
- [65] Pethig, R. (Ed.), 1994. *Valuing the Environment: Methodological and Measurement Issues*, Kluwer.
- [66] Sage, J., 1993. *Industrielle Abfallvermeidung und deren Bewertung; am Beispiel der Leiterplattenherstellung* PhD Thesis (Technische Universitaet Graz; Institut fuer Verfahrenstechnik, Graz, Austria, ISBN 37041-0211-3).
- [67] Heijungs, R. (ed), *op.cit.*
- [68] *ibid.*
- [69] Portney, P.R., 1993–94. The price is right: making use of life cycle analyses, *Issues in Science and Technology*, Winter 1993–94: 69–75.
- [70] Keeney, R.L. and Raiffa, H., 1976. *Decisions with Multiple Objectives: Preferences and Value Tradeoffs*. John Wiley & Sons, New York.
- [71] Goicoechea, A., et al., 1982. *Multiobjective Decision Analysis with Engineering and Business Applications*. John Wiley & Sons, New York.
- [72] Field, F.R. III and Ehrenfeld, J.R., 1994. *Life Cycle Analysis: The Role of Evaluation and Strategy*, Center for Technology, Policy and Industrial Development, Massachusetts Institute of Technology, Cambridge MA, Draft 1994.
- [73] Lubkert, Barbara, Y. Virtanen, M. Muhlberger, I. Ingham, B. Vallance and S. Alber, *op.cit.*
- [74] Habersatter, K. and F. Widmer, *op.cit.*